



# **BlackBerry Connect Messaging APIs Reference**

May 2023



# Contents

|  |          |
|--|----------|
| <b>About this guide.....</b>                 | <b>5</b> |
| <b>Architecture: BEMS-Connect.....</b>       | <b>6</b> |
| <b>What are instant messaging APIs?.....</b> | <b>8</b> |
| Prerequisites.....                           | 8        |
| Privacy settings.....                        | 8        |
| <b>Instant messaging methods.....</b>        | <b>9</b> |
| METHOD_AcceptChat.....                       | 10       |
| METHOD_AcceptFileXfer.....                   | 11       |
| METHOD_AddContact.....                       | 13       |
| METHOD_AddGroup.....                         | 14       |
| METHOD_BeginSession.....                     | 16       |
| METHOD_BlockContact.....                     | 18       |
| METHOD_CopyContactToGroup.....               | 19       |
| METHOD_DeclineChat.....                      | 22       |
| METHOD_DeclineFileXfer.....                  | 23       |
| METHOD_EndChat.....                          | 25       |
| METHOD_GetAuthenticationInfo.....            | 26       |
| METHOD_GetContactDetail.....                 | 27       |
| METHOD_GetContactList.....                   | 29       |
| METHOD_GetContactPhotos.....                 | 31       |
| METHOD_GetContactsState.....                 | 33       |
| METHOD_InviteFileXfer.....                   | 35       |
| METHOD_MessageAck.....                       | 36       |
| METHOD_MoveContact.....                      | 38       |
| METHOD_NotifyBackground.....                 | 39       |
| METHOD_Ping.....                             | 41       |
| METHOD_ReceiveFile.....                      | 43       |
| METHOD_RegisterTempRemotePresence.....       | 44       |
| METHOD_RemoveContact.....                    | 46       |
| METHOD_RemoveContactFromGroup.....           | 48       |
| METHOD_RemoveGroup.....                      | 49       |
| METHOD_RenameGroup.....                      | 51       |
| METHOD_ScheduleNotification.....             | 53       |
| METHOD_SearchDirectory.....                  | 54       |
| METHOD_SendFile.....                         | 57       |
| METHOD_SendMessage.....                      | 58       |
| METHOD_SetGDAuthToken.....                   | 60       |
| METHOD_SetGDToken.....                       | 61       |
| METHOD_SetGNPToken.....                      | 62       |
| METHOD_SetOAuth2Token.....                   | 62       |

|  |    |
|--|----|
| METHOD_SetPersonalMessage.....           | 63 |
| METHOD_SetPresence.....                  | 65 |
| METHOD_StartChat.....                    | 67 |
| METHOD_StartTyping.....                  | 68 |
| METHOD_StopTyping.....                   | 70 |
| METHOD_System.GetServerInfo.....         | 72 |
| METHOD_TerminateSession.....             | 73 |
| METHOD_UnblockContact.....               | 75 |
| METHOD_UnRegisterTempRemotePresence..... | 76 |
| METHOD_UserUpdate.....                   | 78 |

**Adminstrative methods..... 79**

|                                |    |
|--------------------------------|----|
| METHOD_PC_CreateRoom.....      | 79 |
| METHOD_PC_DisableRoom.....     | 83 |
| METHOD_PC_GetCategories.....   | 84 |
| METHOD_PC_GetRoom.....         | 85 |
| METHOD_PC_UpdateRoom.....      | 88 |
| METHOD_PC_UpdateRoomUsers..... | 90 |

**User methods..... 94**

|                                    |     |
|------------------------------------|-----|
| METHOD_PC_FollowRooms.....         | 94  |
| METHOD_PC_GetChatHistory.....      | 96  |
| METHOD_PC_GetMyRooms.....          | 99  |
| METHOD_PC_GetRoomParticipants..... | 101 |
| METHOD_PC_JoinRoom.....            | 103 |
| METHOD_PC_LeaveRoom.....           | 104 |
| METHOD_PC_MuteRooms.....           | 105 |
| METHOD_PC_SearchRooms.....         | 107 |
| METHOD_PC_SendMessage.....         | 109 |
| METHOD_PC_FileUpload.....          | 111 |
| METHOD_PC_FileDownload.....        | 113 |
| Response codes.....                | 114 |

**Event notifications..... 115**

|                                       |     |
|---------------------------------------|-----|
| Event_PC_InvitationReceived.....      | 115 |
| Event_PC_MessageReceived.....         | 116 |
| Event_PC_ParticipantChanged.....      | 117 |
| Event_PC_RefreshContent.....          | 118 |
| Event_PC_RoomSettingsChanged.....     | 121 |
| EVENT_FileXferInvitationReceived..... | 122 |
| Event_FileXferInvitationUpdate.....   | 123 |

**HTTP response codes..... 125**

**Legal notice..... 133**

# About this guide

BEMS-Connect is a secure, mobile, instant messaging application that is built on BlackBerry Dynamics. This guide describes the following:

- BEMS-Connect architecture and the instant messaging data flow from devices to the Enterprise Instant Messaging services including, Skype for Business, and Cisco Unified Communications Manager for IM and Presence
- Instant messaging APIs that allow users to send and receive instant messaging messages
- Persistent chat APIs to allow users to create and participate in topic-based group discussions.

This guide is intended for developers who are responsible for developing code for instant messaging and persistent chat applications. After you read this reference guide, you should understand the methods used in instant messaging and persistent chat group discussions.

# Architecture: BEMS-Connect

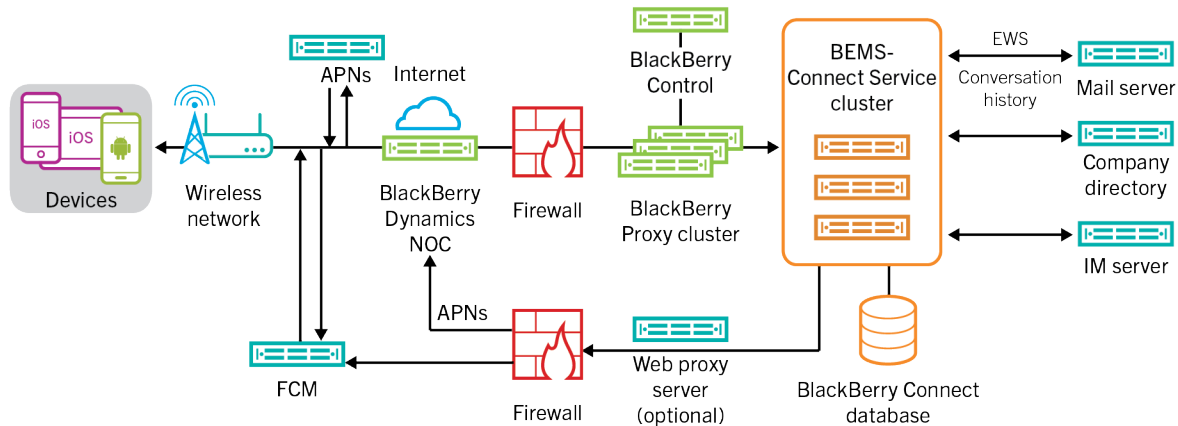

| Component                             | Description  |
|---------------------------------------|--|
| BEMS-Connect                          | The BEMS-Connect service provides secure instant messaging, company directory look-up, and user presence information to iOS and Android devices.   |
| Devices                               | The BEMS-Connect service supports iOS and Android devices.   |
| BlackBerry Dynamics NOC               | The BlackBerry Dynamics NOC provides secure communication between the BlackBerry Connect app on devices and the BEMS-Connect service.  |
| Notification services                 | <p>The BEMS-Connect service queues notifications and sends them to the BlackBerry Dynamics NOC, where they are sent to the devices using the appropriate notification service:</p> <ul style="list-style-type: none"> <li>• APNs is a service that Apple provides to send notifications to iOS devices.</li> <li>• FCM is a service that Google provides to send notifications to Android devices.</li> <li>• Web proxy (optional). If your organization's security policy requires that internal systems cannot make connections directly to the Internet, you can use a web proxy server.</li> </ul> |
| Microsoft Exchange Web Services (EWS) | BEMS-Connect uses Microsoft Exchange Web Services to write the conversation history to the Microsoft Exchange Server over port 443.  |
| BEMS-Connect database                 | <p>The BEMS-Connect database performs the following actions:</p> <ul style="list-style-type: none"> <li>• Maintains the BlackBerry Connect client container session information.</li> <li>• Maintains the list of SIP-enabled users, in environments configured for Skype for Business, or Cisco Unified Communications Manager for IM and Presence.</li> </ul>  |

| Component        | Description   |
|------------------|---|
| BlackBerry Proxy | The BlackBerry Proxy maintains the secure data path connection between the devices and the BEMS-Connect service.  |
| IM server        | BEMS-Connect supports the following instant messaging servers: <ul data-bbox="602 415 868 485" style="list-style-type: none"><li data-bbox="602 415 868 447">• Skype for Business</li><li data-bbox="602 447 868 485">• Cisco Jabber</li></ul> Persistent chat is supported with Skype for Business 2015. |

# What are instant messaging APIs?

The Connect service uses APIs to allow users to send instant messages in a secure, mobile messaging application that is built on BlackBerry Dynamics. The BlackBerry Connect app connects to the organization's instant messaging server and communicates through the BlackBerry Enterprise Mobility Server instance. The instant messaging APIs consist of the following methods:

- [Instant messaging methods](#)
- [Event notifications](#)

Persistent chat group discussion APIs allow BlackBerry Connect app users to create topic-based discussion rooms, referred to as "chat rooms" and "rooms" by Microsoft, and participate in group discussions. The persistent chat APIs consist of the following methods and notifications:

- [Administrative methods](#)
- [User methods](#)
- [Event notifications](#)

## Prerequisites

To use the persistent chat APIs, the following prerequisites must be met:

- The persistent chat feature must be enabled in Skype for Business. Refer to your Skype for Business 2015 documentation for instructions.
- Users must be enabled for persistent chat on BEMS. For instructions, [see the BlackBerry Connect Administration content](#).
- UCMA SDK version 4.0 or later must be installed on the computer hosting the BEMS-Connect service to correspond to connections to Skype for Business2015.
- X-GC-VERSION http header value is set to 2.5.0.0 or later in the API calls. This is the minimum client version where persistent chat related features are enabled on the Connect service.

## Privacy settings

Group discussions can be set to one of the following privacy settings:

- Open: Any users enabled for persistent chat can follow the discussion group without becoming a member.
- Closed: Users must be a member of the discussion group to participate in and receive notifications.
- Secret: Users must be invited to join the discussion group. Secret group discussions that users are not invited to join are not returned in a search query. Users can be invited, but don't need to join the discussion group.



# Instant messaging methods

This section provides information about APIs that complete instant messaging tasks. The following methods are available:

- [METHOD\\_AcceptChat](#)
- [METHOD\\_AcceptFileXfer](#)\*
- [METHOD\\_AddContact](#)
- [METHOD\\_AddGroup](#)
- [METHOD\\_BeginSession](#)
- [METHOD\\_BlockContact](#)
- [METHOD\\_CopyContactToGroup](#)
- [METHOD\\_DeclineChat](#)
- [METHOD\\_DeclineFileXfer](#)\*
- [METHOD\\_EndChat](#)
- [METHOD\\_GetAuthenticationInfo](#)
- [METHOD\\_GetContactDetail](#)
- [METHOD\\_GetContactList](#)
- [METHOD\\_GetContactPhotos](#)
- [METHOD\\_GetContactsState](#)
- [METHOD\\_InviteFileXfer](#)\*
- [METHOD\\_MessageAck](#)
- [METHOD\\_MoveContact](#)
- [METHOD\\_NotifyBackground](#)
- [METHOD\\_Ping](#)
- [METHOD\\_ReceiveFile](#)\*
- [METHOD\\_RegisterTempRemotePresence](#)
- [METHOD\\_RemoveContact](#)
- [METHOD\\_RemoveContactFromGroup](#)
- [METHOD\\_RemoveGroup](#)
- [METHOD\\_RenameGroup](#)
- [METHOD\\_ScheduleNotification](#)
- [METHOD\\_SendMessage](#)
- [METHOD\\_SendFile](#)\*
- [METHOD\\_SearchDirectory](#)
- [METHOD\\_SetGDAuthToken](#) (API version 2.3 or later)
- [METHOD\\_SetGDToken](#)
- [METHOD\\_SetGNPToken](#)
- [METHOD\\_SetOAuth2Token](#)
- [METHOD\\_SetPersonalMessage](#)
- [METHOD\\_SetPresence](#)
- [METHOD\\_StartChat](#)
- [METHOD\\_StartTyping](#)
- [METHOD\\_StopTyping](#)
- [METHOD\\_System.GetServerInfo](#)
- [METHOD\\_TerminateSession](#)
- [METHOD\\_UnblockContact](#)
- [METHOD\\_UnRegisterTempRemotePresence](#)

- [METHOD\\_UserUpdate](#)

\* Methods that support sending and receiving files in one-to-one chats when the Connect service is configured with Skype for Business 2015 or 2019 on-premises using trusted application mode and users are running BlackBerry Connect 3.5 or later.

## METHOD\_AcceptChat

This method allows the BlackBerry Connect app to accept a chat request from a contact and start a conversation.

The following table describes the parameters that you can include in this method.

| Parameter    | Type   | Required | Description   |
|--------------|--------|----------|---|
| requestId    | String | ✓        | This parameter specifies the requestId from the InvitationReceived server notification. |
| dependencies | String | —        | This parameter specifies the other methods that this method is dependent on.            |

### BEMS response and notification

The following table describes the response and notification parameters that BEMS returns when the chat is requested and accepted.

| Parameter | Type   | Description  |
|-----------|--------|--|
| chatId    | String | This parameter returns the requestId of the chat.  |
| method    | String | This parameter returns the invoked method (for example, AcceptChat).                             |
| state     | String | This parameter specifies the state of the request to BEMS (for example, Processing or Complete). |

### Code example

The following example sends a request to BEMS to accept an instant messaging chat request.

```
{
  "method": "AcceptChat",
  "params": {
    "requestId": "dbc2e7b6-25e8-450e-9670-c9e4f32341bb"
  },
  "id": "c5",
  "jsonrpc": "2.0"
}
```

If the request is successful, BEMS returns the following response to the BlackBerry Connect app and processes the request.

```
{
  "id": "c5",
  "error": null,
  "result": {
    {
      "data": {
        "chatId": "dbc2e7b6-25e8-450e-9670-c9e4f32341bb",
        "method": "AcceptChat",
        "state": "PROCESSING"
      }
    }
  },
  "jsonrpc": "2.0",
  "background": true
}
```

If there are no errors, BEMS sends the following notification to the BlackBerry Connect app and the chat is started.

```
{
  "id": "c5",
  "sequence": 1018540600000022,
  "result": {
    {
      "data": {
        "chatId": "dbc2e7b6-25e8-450e-9670-c9e4f32341bb",
        "method": "AcceptChat",
        "state": "COMPLETE"
      }
    }
  },
  "jsonrpc": "2.0"
}
```

## METHOD\_AcceptFileXfer

This method allows the recipient in the one-to-one chat to accept the file transfer from the sender.

The following table lists the parameters that you can include in this method.

| Parameter | Type   | Required | Description  |
|-----------|--------|----------|--|
| contactid | String | √        | This parameter specifies the ID of the contact that sends the file.                        |
| fileid    | String | √        | This parameter specifies the file ID created by the BlackBerry Connect client for the file |

### BEMS response and notification

The following table describes the parameters that BEMS returns and the notification sent to the BlackBerry Connect app when the recipient accepts the file invitation and the file is sent.

| Parameter | Type   | Description   |
|-----------|--------|---|
| chatId    | String | This parameter specifies the ID of the chat that the file transfer invite is sent to.             |
| method    | String | This parameter specifies the invoked method (for example, AcceptFileXfer).                        |
| state     | String | This parameter specifies the state of the request to BEMS (for example, Processing or Completed). |

### Code example

The following example sends a request to BEMS to accept the file transfer from "user1" in the chat.

```
{
  "method": "AcceptFileXfer",
  "params":
  {
    "contactId": "sip:user1@example.com",
    "fileId": "dbc2e7b6-25e8-450e-9670-c9e4f32341bb"
  },
  "id": "c55",
  "jsonrpc": "2.0"
}
```

If the request is successful, BEMS sends the following response to the BlackBerry Connect app and processes the request.

```
{
  "id": "c55",
  "error": null,
  "result":
  {
    "data":
    {
      "method": "AcceptFileXfer",
      "state": "PROCESSING"
    }
  },
  "jsonrpc": "2.0"
}
```

If there are no errors, BEMS sends the following notification to the BlackBerry Connect app and sends the file to the recipient.

```
{
  "id": "c55",
  "error": null,
  "result":
  {
    "data":
    {
      "method": "AcceptFileXfer",
      "state": "COMPLETED"
    }
  },
  "jsonrpc": "2.0"
}
```

```
}
```

## METHOD\_AddContact

This method adds a contact to the user's BlackBerry Connect app contact list.

The following table describes the parameters that you can include in this method.

| Parameter    | Type   | Required | Description  |
|--------------|--------|----------|--|
| contactId    | String | ✓        | This parameter specifies the ID of the contact to add to the contact list.   |
| groupId      | String | —        | This parameter specifies the group ID to add to the contact list.            |
| dependencies | String | —        | This parameter specifies the other methods that this method is dependent on. |

### BEMS response and notification

The following table describes the parameters that BEMS returns and the notification sent to the BlackBerry Connect app when the contact is added.

| Parameter | Type   | Description  |
|-----------|--------|--|
| method    | String | This parameter specifies the invoked method (for example, the AddContact method).                |
| state     | String | This parameter specifies the state of the request to BEMS (for example, Processing or Complete). |

### Code example

The following example sends a request to BEMS to add user1 to the user's BlackBerry Connect app contact list.

```
{
  "method": "AddContact",
  "params":
  {
    "contactId": "sip:user1@example.com"
  },
  "id": "c55",
  "jsonrpc": "2.0"
}
```

If the request is successful, BEMS returns the following response to the BlackBerry Connect app and processes the request.

```
{
  "id": "c55",
  "error": null,
}
```

```

"result":
{
  "data":
  {
    "method": "AddContact",
    "state": "PROCESSING"
  }
},
"jsonrpc": "2.0",
"background": true
}

```

If there are no errors, BEMS sends the following notification to the BlackBerry Connect app and adds the contact.

```

{
  "id": "c55",
  "sequence": 1018541300000024,
  "result":
  {
    "data":
    {
      "method": "AddContact",
      "state": "COMPLETE"
    }
  },
  "jsonrpc": "2.0"
}

```

## METHOD\_AddGroup

This method adds a group to the BlackBerry Connect app contact list.

The following table describes the parameters that you can include in this method.

| Parameter    | Type   | Required | Description  |
|--------------|--------|----------|--|
| groupName    | String | ✓        | Specifies the group name to add to the contact list.                         |
| dependencies | String | —        | This parameter specifies the other methods that this method is dependent on. |

### BEMS response and notification

The following table describes the parameters that BEMS returns and the notification sent to the BlackBerry Connect app when a group is added.

| Parameter | Type   | Description   |
|-----------|--------|---|
| method    | String | This parameter specifies the invoked method (for example, AddGroup).                              |
| state     | String | This parameter specifies the state of the request to BEMS (for example, Processing and Complete). |

| Parameter | Type   | Description  |
|-----------|--------|--|
| message   | String | This parameter specifies the message that is sent to the BlackBerry Connect app with the notification. |

### Code example

The following example sends a request to BEMS to add the group, "TeamBuilding", to the user's BlackBerry Connect app contact list.

```
{
  "method": "AddGroup",
  "params":
  {
    "groupName": "TeamBuilding"
  },
  "id": "c55",
  "jsonrpc": "2.0"
}
```

If the request is successful, BEMS returns the following response to the BlackBerry Connect app and processes the request.

```
{
  "id": "c55",
  "error": null,
  "result": {
    "data":
    {
      "method": "AddGroup",
      "state": "PROCESSING"
    }
  },
  "jsonrpc": "2.0",
  "background": true
}
```

If there are no errors, the BEMS returns the following notification to the BlackBerry Connect app and adds the group.

```
{
  "id": "c55",
  "sequence": 1018547700000027,
  "result":
  {
    "data":
    {
      "message": "The group name exampleGroup is created",
      "method": "AddGroup",
      "state": "COMPLETE"
    }
  },
  "jsonrpc": "2.0"
}
```

## METHOD\_BeginSession

This method notifies BEMS that the BlackBerry Connect app wants to start a chat session. This method replaces the login method because it is using single sign-on. Make sure to use the appropriate parameters based on the version of API you are using.

The following table describes the parameters that you can include in this method.

| Parameter  | Type    | Required | Description   |
|--|---------|----------|---|
| userId   | String  | √*       | This parameter is deprecated in API version 2.3 or later.<br>If you are using API version 2.2 or earlier, this parameter specifies the authoring BlackBerry Dynamics user ID in the BlackBerry Dynamics framework.  |
| gdAuthToken<br>* Use this parameter if you are using the API version 2.3 or later. | String  | √        | This parameter specifies the BlackBerry Dynamics authToken that the BlackBerry Connect app retrieves from getGDAuthToken and presents it to BEMS for authentication.<br><b>Note:</b> BEMS uses the user identity extracted from the gdAuthToken only.   |
| gdToken<br>* Use this parameter if you are using the API version 2.2 or earlier.   | Strong  | √        | This parameter specifies the BlackBerry Dynamics token that the BlackBerry Connect app retrieves from Good Proxy and presents it to BEMS for authentication.  |
| deviceToken  | String  | —        | This parameter specifies a unique identifier for the BlackBerry Connect app. If the BlackBerry Connect app doesn't create a deviceToken, the BEMS server creates a GUID token and adds it to the Cookie (deviceToken) on the response to the BlackBerry Connect app.  |
| presence   | String  | —        | This parameter specifies the presence status that is used when the session is initiated (for example, available).   |
| personalMessage  | String  | —        | This parameter specifies the personal message that is set when the session is initiated.  |
| gnpToken   | String  | —        | This parameter specifies the value of the GNP token. The BlackBerry Connect app retrieves the token from the BlackBerry Dynamics client API and sends it to the BEMS-Connect server for use in push notifications. The BEMS-Connect server confirms the validity of the token with the BlackBerry Proxy server. |
| pushMaxLength  | Integer | —        | This parameter specifies the maximum payload size for the FCM and APNs notifications.   |



| Parameter                      | Type    | Required | Description   |
|--------------------------------|---------|----------|---|
| sequence                       | Integer | –        | This parameter specifies the unique sequence number for tracking purposes.                |
| lastPersistentChatInvitationId | Integer | –        | This parameter specifies the ID of the last persistent chat invitation that was received. |

### BEMS response and notification

The following table describes the parameters that BEMS returns and the notification sent to the BlackBerry Connect app when a chat session is started.

| Parameter | Type   | Description  |
|-----------|--------|--|
| method    | String | This parameter returns the invoked method (for example, BeginSession).                           |
| state     | String | This parameter specifies the state of the request to BEMS (for example, Processing or Complete). |
| sessionId | String | This parameter specifies the session ID for the user.  |

### Code example

The following example sends a request to begin BEMS to begin an instant messaging chat session.

```
{
  "id": "c12",
  "method": "BeginSession",
  "params": {
    "userId": "user1@example.com",
    "gdAuthToken": "thegdauthtokengeneratedbybd",
    "deviceToken": "thetokengeneratedbydevice",
    "presence": "available",
    "personalMessage": "I am available"
  },
  "jsonrpc": "2.0"
}
```

If the request is successful, BEMS sends the following response to the BlackBerry Connect app and processes the request.

```
{
  "id": "c12",
  "error": null,
  "result": {
    "data": {
      "method": "BeginSession",
      "state": "PROCESSING"
    }
  },
}
```

```

"jsonrpc": "2.0",
"background": false
}

```

If there are no errors, BEMS sends the following notification to the BlackBerry Connect app and the session starts.

```

{
  "id": "c12",
  "sequence": 1018528500000011,
  "result":
  {
    "data":
    {
      "sessionId": "af949a36-b61d-43d7-bb44-aa4c003ddc1a",
      "method": "BeginSession",
      "state": "COMPLETE"
    }
  },
  "jsonrpc": "2.0"
}

```

## METHOD\_BlockContact

This method notifies BEMS that the user wants to block a contact on the user's contact list. Users can block users that are a part of their contact list as well as those that are not a part of the contact list.

| Parameter    | Type   | Required | Description   |
|--------------|--------|----------|---|
| contactId    | String | ✓        | <p>This parameter specifies the user ID of the user to block in the contact list.</p> <p><b>Note:</b> If a user blocks another user, the user that initiates the block doesn't receive ContactUpdate notifications for the blocked user. However, if the user has other active sessions with the blocked user, they still receive ContactUpdates for the blocked user in those sessions. The user can get the blocked user's status by searching for their contact details.</p> |
| dependencies | String | —        | This parameter specifies the other methods that this method is dependent on.  |

### BEMS response and notification

The following table describes the parameters that BEMS returns and the notification sent to the BlackBerry Connect app when the contact is blocked.

| Parameter | Type   | Description  |
|-----------|--------|--|
| method    | String | This parameter specifies the invoked method (for example, BlockContact).                         |
| state     | String | This parameter specifies the state of the request to BEMS (for example, Processing or Complete). |

## Code example

The following example sends a request to BEMS to block "user33" in the BlackBerry Connect app contact list.

```
{
  "id": "c12",
  "method": "BlockContact",
  "params":
  {
    "contactIds": {"user33@example.com"}
  },
  "id": "c55",
  "jsonrpc": "2.0"
}
```

If the request is successful, BEMS sends the following response to the BlackBerry Connect app and processes the request.

```
{
  "id": "c55",
  "error": null,
  "result":
  {
    "data":
    {
      "method": "BlockContact",
      "state": "PROCESSING"
    }
  },
  "jsonrpc": "2.0"
  "background": true
}
```

If there are no errors, BEMS sends the following notification to the BlackBerry Connect app and the contact is blocked.

```
{
  "id": "c55",
  "sequence": 1018548300000029,
  "result":
  {
    "data":
    {
      "method": "BlockContact",
      "state": "COMPLETE"
    }
  },
  "jsonrpc": "2.0"
}
```

## METHOD\_CopyContactToGroup

Use this method to copy an existing contact to a group.

The following table lists the parameters that you can include in this method.

| Parameter    | Type   | Required | Description  |
|--------------|--------|----------|--|
| contactId    | String | ✓        | This parameter specifies the contact's ID to add to the group.   |
| groupId      | String | ✓        | This parameter specifies the id of the group to which the contact is added.  |
| dependencies | String | —        | This parameter specifies the other methods that this method is dependent on. It specifies the comma delimited dependent request IDs.   |
| reconnect    | String | —        | This parameter specifies that the BlackBerry Connect app re-establish the existing session. For example, when BlackBerry Connect goes to the background and returns to the foreground the same session is continued. |

### BEMS response and notification

The following table describes the parameters that BEMS returns and the notification sent to the BlackBerry Connect app when the contact is added to a group.

| Parameter | Type   | Description  |
|-----------|--------|--|
| method    | String | This parameter specifies the invoked method (for example, CopyContactToGroup).                       |
| state     | String | This parameter specifies the state of the request to BEMS (for example, Processing or Complete).     |
| message   | String | This parameter specifies the message that is sent to the BlackBerry Connect app in the notification. |

### Code example

The following code example sends a request to BEMS to add "user33" to the "TeamBuilding" group in the BlackBerry Connect app contact list.

```
{
  "method": "CopyContactToGroup",
  "params": {
    "contactId": "sip:user33@example.com",
    "groupId": "15"
  },
  "id": "c55",
  "jsonrpc": "2.0"
}
```

BEMS processes the request and sends the following response to the BlackBerry Connect app.

```
{
  "id": "c55",
```

```

"error":null,
"result":
{
  "data":
  {
    "method":"CopyContactToGroup",
    "state":"PROCESSING"
  }
},
"jsonrpc":"2.0"
"background":true
}

```

If the user is already in the group, BEMS sends the following response to the BlackBerry Connect app and the contact is not added to the group.

```

{
  "id": "c55",
  "error":
  {
    "code":"16005",
    "message": "Contact is already in the destination group.",
    "data":
    {
      "method":"CopyContactToGroup"
    }
  },
  "result":null,
  "jsonrpc":"2.0",
  "background":true
}

```

If the user isn't in the group and there are no errors, BEMS sends the following response to the BlackBerry Connect app and the contact is added to the group.

```

{
  "id": "c55",
  "sequence":1018551200000040,
  "result":
  {
    "data":
    {
      "message":"Add contact to group success.",
      "method":"CopyContactToGroup",
      "state":"COMPLETE"
    }
  },
  "jsonrpc": "2.0"
}

```

If an error is encountered, BEMS sends the following response to the BlackBerry Connect app and the contact isn't added to the group.

```

{
  "id": "c55",
  "sequence":1018549700000031,
  "error":
  {
    "code":"1005",

```

```

    "message": "BEMS-Connect has encounter an error serving the request.",
    "data":
      {
        "method": "CopyContactToGroup",
        "state": "ERROR"
      }
  },
  "jsonrpc": "2.0"
}

```

## METHOD\_DeclineChat

Use this method to decline a chat request from a user.

The following table describes the parameters that you can include in this method.

| Parameter    | Type   | Required | Description   |
|--------------|--------|----------|---|
| requestId    | String | ✓        | This parameter specifies the requestId from the InvitationReceived server notification.   |
| dependencies | String | —        | This parameter specifies the other methods that this method is dependent on. It specifies the comma delimited dependent request IDs.  |
| reconnect    | String | —        | This parameter specifies that the BlackBerry Connect app re-establish the existing session. For example, if BlackBerry Connect goes to the background, when it comes to the foreground the same session is continued. |

### BEMS response and notification

The following table describes the parameters that BEMS returns and the notification to send to the BlackBerry Connect app when a chat invitation is declined.

| Parameter | Type   | Description  |
|-----------|--------|--|
| state     | String | This parameter specifies the state of the request to BEMS (for example, Processing or Complete). |
| method    | String | This parameter specifies the method invocation name (for example, DeclineChat).                  |

### Code example

The following example sends a request to BEMS to decline a chat request.

```

{
  "method": "DeclineChat",
  "params":
  {

```

```

    "requestId": "dbc2e7b6-25e8-450e-9670-c9e4f32341bb"
  },
  "id": "c5",
  "jsonrpc": "2.0"
}

```

If the decline request is successful, BEMS sends the following response to the BlackBerry Connect app and processes the request.

```

{
  "id": "c5",
  "error": null,
  "result":
  {
    "data":
    {
      "method": "DeclineChat",
      "state": "PROCESSING"
    }
  },
  "jsonrpc": "2.0"
  "background": true
}

```

If there are no errors, BEMS sends the following notification to the BlackBerry Connect app and the declines the chat request.

```

{
  "id": "c5",
  "sequence": 1018552300000042,
  "result":
  {
    "data":
    {
      "method": "DeclineChat",
      "state": "COMPLETE"
    }
  },
  "jsonrpc": "2.0"
}

```

## METHOD\_DeclineFileXfer

This method declines the file transfer invitation from the sender in a one-to-one chat.

The following table lists the parameters that you can include in this method.

| Parameter | Type   | Required | Description   |
|-----------|--------|----------|---|
| contactid | String | √        | This parameter specifies the ID of the contact that sends the file.                         |
| fileid    | String | √        | This parameter specifies the file ID created by the BlackBerry Connect client for the file. |

## BEMS response and notification

The following table describes the parameters that BEMS returns and the notification sent to the BlackBerry Connect app when the file is declined.

| Parameter | Type   | Description   |
|-----------|--------|---|
| chatId    | String | This parameter returns the ID of the chat that the file transfer invite is sent to.               |
| method    | String | This parameter specifies the invoked method (for example, DeclineFileXfer).                       |
| state     | String | This parameter specifies the state of the request to BEMS (for example, Processing or Completed). |

## Code example

The following example sends a request to BEMS to decline the file transfer from "user1" in the chat.

```
{
  "method": "DeclineFileXfer",
  "params": {
    "contactId": "sip:user1@example.com",
    "fileId": "dbc2e7b6-25e8-450e-9670-c9e4f32341bb"
  },
  "id": "c55",
  "jsonrpc": "2.0"
}
```

If the request is successful, BEMS sends the following response to the BlackBerry Connect app and processes the request.

```
{
  "id": "c55",
  "error": null,
  "result": {
    "data": {
      "method": "DeclineFileXfer",
      "state": "PROCESSING"
    }
  },
  "jsonrpc": "2.0"
}
```

If there are no errors, BEMS sends the following notification to the BlackBerry Connect app and declines the file.

```
{
  "id": "c55",
  "error": null,
  "result": {
    "data": {
      "method": "DeclineFileXfer",

```



```

        "state": "COMPLETED"
    },
    "jsonrpc": "2.0"
}

```

## METHOD\_EndChat

Use this method to notify BEMS that the user app is ending the chat session.

The following table describes the parameters that you can include in this method.

| Parameter    | Type   | Required | Description   |
|--------------|--------|----------|---|
| contactId    | String | ✓        | This parameter specifies the unique instant messaging session ID.   |
| dependencies | String | —        | This parameter specifies the other methods that this method is dependent on. It specifies the comma delimited dependent request ids.  |
| reconnect    | String | —        | This parameter specifies that the BlackBerry Connect app re-establish the existing session. For example, when BlackBerry Connect goes to the background and returns to the foreground the same session continues. |

### BEMS response and notification

The following table describes the parameters that BEMS returns and the notification to send to the BlackBerry Connect app when the chat ends.

| Parameter | Type   | Description  |
|-----------|--------|--|
| state     | String | This parameter specifies the state of the request to BEMS (for example, Processing or Complete). |
| method    | String | This parameter specifies the method invocation name (for example, EndChat).                      |

### Code example

The following example sends an end chat request to BEMS.

```

{
  "method": "EndChat",
  "params":
  {
    "contactId": "contact@example.com"
  },
  "id": "c5",
  "jsonrpc": "2.0"
}

```

If the request is successful, BEMS sends the following response to the BlackBerry Connect app and processes the request.

```
{
  "id": "c5",
  "error": null,
  "result": {
    "data": {
      {
        "method": "EndChat",
        "state": "PROCESSING"
      }
    },
    "jsonrpc": "2.0",
    "background": true
  }
}
```

If there are no errors, BEMS sends the following response to the BlackBerry Connect app and the chat ends.

```
{
  "id": "c5",
  "sequence": 1018553700000047,
  "result": {
    "data": {
      {
        "method": "EndChat",
        "state": "COMPLETE"
      }
    },
    "jsonrpc": "2.0"
  }
}
```

## METHOD\_GetAuthenticationInfo

This method sends a query to BEMS for authentication related information for Microsoft Entra ID tasks. For example,

- If the environment uses Skype for Business on-premises, BEMS returns a login url. Auto discovery must be enabled.
- If the environment uses Skype for Business using non-trusted application mode, no authentication information is returned.
- If the environment uses Cisco Unified Communications Manager for IM and Presence.

Call this method before the [METHOD\\_BeginSession](#) so that an access token can be generated.

| Parameter   | Type   | Required | Description  |
|-------------|--------|----------|--|
| GDAuthToken | String | ✓        | This parameter specifies the access token that is generated for BlackBerry Dynamics apps.<br><br>This parameter can be passed in instead of through the X-Good-GD-AuthToken. |

## BEMS response and notification

The following table describes the parameters that BEMS returns, and the notification sent to the BlackBerry Connect app when a chat session is started.

| Parameter    | Type   | Description  |
|--------------|--------|--|
| authDataType | String | Returns the authentication information that is used in the access token.                         |
| method       | String | Returns the invoked method (for example, GetAuthenticationInfo).                                 |
| state        | String | This parameter specifies the state of the request to BEMS (for example, Processing or Complete). |

## Code example

The following example sends a query to BEMS to obtain authentication information to generate an access token.

```
{
  "id": "c1",
  "method": "GetAuthenticationInfo",
  "params": {
    "gdAuthToken": "d64a57b7-f5b5-4e3a-839b-00618653a090"
  },
  "jsonrpc": "2.0"
}
```

If the request is successful, BEMS sends the following response to the BlackBerry Connect app and processes the request.

```
{
  "id": "c1",
  "error": null,
  "result": {
    "data": {
      "method": "GetAuthenticationInfo",
      "loginUrl": "https://webext.gems.cbbcps.com/WebTicket/oauthToken",
      "authDataType": "WindowsAccessToken",
      "state": "COMPLETE"
    }
  },
  "jsonrpc": "2.0"
}
```

## METHOD\_GetContactDetail

This method retrieves the contact card information for a contact in the BlackBerry Connect app contact list.

The following table describes the parameters that you can include in this method.

| Parameter | Type   | Required | Description   |
|-----------|--------|----------|---|
| contactId | String | ✓        | This parameter specifies the contact ID of the contact that the contact card information is requested from. |

### BEMS response and notification

The following table describes the parameters that BEMS returns and the notification to send to the BlackBerry Connect app when a contact's information is retrieved.

| Parameter | Type   | Description   |
|-----------|--------|---|
| state     | String | This parameter specifies the state of the request to BEMS (for example, Processing or Complete).                  |
| method    | String | This parameter specifies the method invocation name (for example, GetContactDetail).                              |
| contact   | Object | This parameter specifies the contact's information (for example, display name, email address, and mobile number). |

### Code example

The following example sends a request to BEMS to retrieve "user1's" contact card information.

```
{
  "method": "GetContactDetail",
  "params": {
    "contactId": "user1@example.com"
  },
  "id": "c5",
  "jsonrpc": "2.0"
}
```

If the request is successful, BEMS sends the following response to the BlackBerry Connect app and processes the request.

```
{
  "id": "c5",
  "error": null,
  "result": {
    "data": {
      "method": "GetContactDetail"
      "state": "PROCESSING"
    }
  },
  "jsonrpc": "2.0"
}
```

If there are no errors, BEMS sends the following notification to the BlackBerry Connect app and the contact's information is displayed.

```
{
  "id": "C5",
  "sequence": 948030700001213,
  "result":
  {
    "data":
    {
      "method": "GetContactDetail",
      "contact":
      {
        "sip:user1@example.com":
        {
          "displayName": "user1",
          "groups": [ ],
          "personalMessage": "I'm out of office today.",
          "availability": "18500",
          "title": "",
          "type": "unknown",
          "uri": "sip:user1@example.com",
          "photoHash": "PENDING",
          "numDevices": "1",
          "mobilePhone": "",
          "blocked": "true",
          "workPhone": "",
          "presence": "Offline",
          "email": "user1@example.com"
        }
      }
    },
    "state": "COMPLETE"
  },
  "jsonrpc": "2.0"
}
```

## METHOD\_GetContactList

This method retrieves the contact list of the user.

The following table describes the parameters that you can include in this method.

| Parameter    | Type   | Required | Description   |
|--------------|--------|----------|---|
| dependencies | String | —        | This parameter specifies the other methods that this method is dependent on. It specifies the comma delimited dependent request IDs.  |
| reconnect    | String | —        | This parameter specifies that the BlackBerry Connect app re-establish the existing session. For example, if BlackBerry Connect goes to the background, when it comes to the foreground the same session is continued. |

## BEMS response and notification

The following table describes the parameters that BEMS returns when the BlackBerry Connect app retrieves the user's contact list and the notification that is sent to the BlackBerry Connect app.

| Parameter | Type   | Description  |
|-----------|--------|--|
| method    | String | This parameter specifies the invoked method (for example, GetContactList).   |
| state     | String | This parameter specifies the state of the request to BEMS (for example, Processing and Complete).                          |
| contacts  | Object | This parameter specifies the key value pair of the contacts for the user. The key values are the SIP URI for each contact. |

### Code example

The following example sends a request to BEMS to retrieve all contacts in the user's contact list.

```
{
  "method": "GetContactList",
  "params": {},
  "id": "c11",
  "jsonrpc": "2.0"
}
```

If the request is successful, BEMS returns the following response to the BlackBerry Connect app.

```
{
  "id": "c11",
  "error": null,
  "result": {
    "data": {
      "method": "GetContactList",
      "state": "PROCESSING"
    }
  },
  "jsonrpc": "2.0"
}
```

If there are no errors, BEMS sends the following notification to the BlackBerry Connect app and the user's contact list is displayed.

```
{
  "id": "c11",
  "sequence": 1018528500000011,
  "result": {
    "data": {
      "contacts": {},
      "method": "GetContactList",
      "state": "COMPLETE"
    }
  }
}
```

```

},
"jsonrpc": "2.0"
}

```

## METHOD\_GetContactPhotos

This method sends a request to BEMS to retrieve the photos or avatars associated with a user's contacts in the BlackBerry Connect app contact list.

The following table describes the parameters that you can include in this method.

| Parameter    | Type      | Required | Description   |
|--------------|-----------|----------|---|
| contactIds   | JsonArray | ✓        | This parameter specifies an array of contact IDs to retrieve the photo data for.  |
| dependencies | String    | —        | This parameter specifies the other methods that this method is dependent on. It specifies the comma delimited dependent request ids.  |
| reconnect    | String    | —        | This parameter specifies that the BlackBerry Connect app re-establish the existing session. For example, if BlackBerry Connect goes to the background, when it comes to the foreground the same session is continued. |

### BEMS response and notification

The following table describes the parameters that BEMS returns and the notifications to send to the BlackBerry Connect app when the contacts' photos or avatars are retrieved.

| Parameter | Type      | Description  |
|-----------|-----------|--|
| method    | String    | This parameter specifies the method invoked (for example, GetContactPhotos).                     |
| state     | String    | This parameter specifies the state of the request to BEMS (for example, Processing or complete). |
| contacts  | JsonArray | This parameter specifies a list of the contacts' photos or avatars.                              |

### Example code

The following example sends a request to BEMS to return the contacts' photo or avatar for the contacts in the contact list.

```

{
  "id": "c12",
  "method": "GetContactPhotos",
  "params":
  {
    "contactIds": [ "user1@example.com", "user2@example.com",
"user3@example.com" ]
  }
}

```

```

    },
    "jsonrpc": "2.0"
  }

```

If the request is successful, BEMS sends the following response to the BlackBerry Connect app and processes the request.

```

{
  "id": "c12",
  "error": null,
  "result": {
    "data": {
      "method": "GetContactPhotos",
      "state": "PROCESSING"
    }
  },
  "jsonrpc": "2.0",
  "background": true
}

```

If there are no errors, BEMS sends the following notification to the BlackBerry Connect app and the contact's photos or avatars are displayed.

**Note:** If contacts do not have photo or avatar, or are invalid contacts, the notification returns an empty value.

```

{
  "id": "c12",
  "sequence": 1018557800000049,
  "result": {
    "data": {
      "contacts": {
        "user1@example.com": {
          "photoHash": "0123456789abcdef...", // hex encoded md5 hash of
          photo data(32 bytes hex)
          "photoData": "<base64 encoded image data>"
        },
        "user2@example.com": {
          "photoHash": "0123456789abcdef...",
          "photoData": "<base64 encoded image data>"
        },
        "user3@example.com": {
          "photoHash": "",
          "photoData": ""
        }
      }
    },
    "method": "GetContactPhotos",
    "state": "COMPLETE"
  },
  "jsonrpc": "2.0"
}

```



## METHOD\_GetContactsState

This method sends a request to BEMS to retrieve a one-time updated presence status of the user's contacts in the BlackBerry Connect app contacts list.

The following table describes the parameters that you can include in this method.

| Parameter    | Type      | Required | Description   |
|--------------|-----------|----------|---|
| contactIds   | JsonArray | ✓        | This parameter specifies an array of contact IDs of the user for which to retrieve the state of the users in the contact list.  |
| dependencies | String    | —        | This parameter specifies the other methods that this method is dependent on. It specifies the comma delimited dependent request ids.  |
| reconnect    | String    | —        | This parameter specifies that the BlackBerry Connect app re-establish the existing session. For example, if BlackBerry Connect goes to the background, when it comes to the foreground the same session is continued. |

### BEMS response and notification

The following table describes the parameters that BEMS returns and the notification to send to the BlackBerry Connect app when the contact's state is retrieved.

| Parameter | Type      | Description   |
|-----------|-----------|---|
| method    | String    | This parameter specifies the method invoked (for example, GetContactState).                       |
| state     | String    | This parameter specifies the state of the request to BEMS (for example, Processing or Complete).  |
| userId    | String    | This parameter specifies the user ID of the user making the request.                              |
| contacts  | JsonArray | This parameter specifies the updated presence status of the contacts in the user's contacts list. |

### Example code

The following example sends a request to BEMS to retrieve the user's contacts presence status.

```
{
  "id": "c12",
  "method": "GetContactsState",
  "params": {
    "contactIds": [{"sip:user1@example.com", "sip:user2@example.com",
  "sip:user3@example.com"}]
  },
  "jsonrpc": "2.0"
}
```

```
}
```

If the request is successful, BEMS sends the following response to the BlackBerry Connect app and processes the request.

```
{
  "id": "c12",
  "error": null,
  "result":
  {
    "data":
    {
      "method": "GetContactsState",
      "state": "PROCESSING"
    }
  },
  "jsonrpc": "2.0",
  "background": true
}
```

If there are no errors, BEMS sends the following notification and a one-time updated presence for all contact's in the user's contact list is displayed.

```
{
  "id": "c21",
  "sequence": 1018557800000049,
  "result":
  {
    "data":
    {
      "contacts":
      {
        "user1@example.com":
        {
          "availability": "15500",
          "presence": "Away"
        },
        "user2@example.com":
        {
          "availability": "6500",
          "presence": "Busy"
        },
        "user3@example.com":
        {
          "availability": "3500",
          "presence": "Available"
        }
      }
    },
    "method": "GetContactsState",
    "state": "COMPLETE"
  },
  "jsonrpc": "2.0"
}
```

## METHOD\_InviteFileXfer

This method sends an invitation to accept a file to the recipient in a one-to-one chat.

The following table lists the parameters that you can include in this method.

| Parameter | Type   | Required | Description   |
|-----------|--------|----------|---|
| contactId | String | ✓        | This parameter specifies the ID of the contact that sends the file.                         |
| fileName  | String | ✓        | This parameter specifies the name of the file to send.                                      |
| fileSize  | Long   | ✓        | This parameter specifies the size of the file to send.                                      |
| fileId    | String | ✓        | This parameter specifies the file ID created by the BlackBerry Connect client for the file. |

### BEMS response and notification

The following table describes the parameters that BEMS returns and the notification sent to the BlackBerry Connect app when a file transfer invitation is sent to the recipient.

| Parameter | Type   | Description   |
|-----------|--------|---|
| chatId    | String | This parameter specifies the ID of the chat that the file transfer invite is sent to.             |
| method    | String | This parameter specifies the invoked method (for example, InviteFileXfer).                        |
| state     | String | This parameter specifies the state of the request to BEMS (for example, Processing or Completed). |

### Code example

The following example sends a request to BEMS to send an file transfer invitation from "user1" in the chat.

```
{
  "method": "InviteFileXfer",
  "params": {
    "contactId": "sip:user1@example.com",
    "fileName": "MyFile.txt",
    "fileSize": 55550000,
    "fileId": "dbc2e7b6-25e8-450e-9670-c9e4f32341bb"
  },
  "id": "c55",
  "jsonrpc": "2.0"
}
```

If the request is successful, BEMS sends the following response to the BlackBerry Connect app and processes the request.

```
{
```

```

{id": "c55",
"error": null,
"result":
  {
    "data":
      {
        "method": "InviteFileXfer",
        "state": "PROCESSING"
      }
  },
"jsonrpc": "2.0"
}

```

If there are no errors, BEMS sends the following notification to the BlackBerry Connect app and sends the file.

```

{
  "id": "c55",
  "error": null,
  "result":
    {
      "data":
        {
          "method": "InviteFileXfer",
          "state": "COMPLETED"
        }
    },
  "jsonrpc": "2.0"
}

```

## METHOD\_MessageAck

This method sends an acknowledgement (delivery receipt) to BEMS for the message that was received by the BlackBerry Connect app.

The following table describes the parameters that you can include in this method.

| Parameter    | Type   | Required | Description   |
|--------------|--------|----------|---|
| messageId    | String | ✓        | This parameter specifies the message ID which the BlackBerry Connect app has obtained from the MessageReceived event.   |
| status       | String | ✓        | This parameter specifies a status of 'delivered.'<br><b>Note:</b> Delivered is currently the only supported status option.  |
| dependencies | String | —        | This parameter specifies the other methods that this method is dependent on. It specifies the comma delimited dependent request ids.  |
| reconnect    | String | —        | This parameter specifies that the BlackBerry Connect app re-establish the existing session. For example, if BlackBerry Connect goes to the background, when it comes to the foreground the same session is continued. |

## BEMS response and notification

The following table describes the parameters that BEMS returns and the notification that is sent to the BlackBerry Connect app when the the acknowledgement is sent.

| Parameter | Type   | Description  |
|-----------|--------|--|
| state     | String | This parameter specifies the state of the request to BEMS (for example, Processing or Complete). |
| method    | String | This parameter specifies the method invocation name (for example, MessageAck).                   |

### Example code

The following example sends a request to BEMS to send an acknowledge (for example, delivery receipt) for a received message.

```
{
  "method": "MessageAck",
  "params":
  {
    "messageId": "1",
    "status": "delivered"
  },
  "id": "c5",
  "jsonrpc": "2.0"
}
```

If the request is successful, BEMS sends the following response to the BlackBerry Connect app and processes the request.

```
{
  "id": "c5",
  "error": null,
  "result":
  {
    "data":
    {
      "method": "MessageAck",
      "state": "PROCESSING"
    }
  },
  "jsonrpc": "2.0",
  "background": false
}
```

If there are no errors, BEMS sends the following notification to the BlackBerry Connect app that acknowledges the receipt of the message.

```
{
  "id": "c5",
  "sequence": 1018561500000012,
  "result":
  {
    "data":
```

```

    {
      "method": "MessageAck",
      "state": "COMPLETE"
    },
    "jsonrpc": "2.0"
  }

```

## METHOD\_MoveContact

This method sends a request to BEMS to move a contact from one group to another group.

The following table describes the parameters that you can include in this method.

| Parameter    | Type   | Required | Description   |
|--------------|--------|----------|---|
| contactId    | String | ✓        | This parameter specifies the contact ID of the contact to move between groups.  |
| fromGroupId  | String | ✓        | This parameter specifies the group ID that the contact exists in.   |
| toGroupId    | String | ✓        | This parameter specifies the group ID of the group that the contact is moving to.   |
| dependencies | String | —        | This parameter specifies the other methods that this method is dependent on. It specifies the comma delimited dependent request ids.  |
| reconnect    | String | —        | This parameter specifies that the BlackBerry Connect app re-establish the existing session. For example, if BlackBerry Connect goes to the background, when it comes to the foreground the same session is continued. |

### BEMS response and notification

The following table describes the parameters that BEMS returns and the notification that is sent to the BlackBerry Connect app when a contact is moved between groups.

| Parameter | Type   | Description  |
|-----------|--------|--|
| state     | String | This parameter specifies the state of the request to BEMS (for example, Processing or Complete). |
| method    | String | This parameter specifies the method invocation name (for example, MoveContact).                  |
| message   | String | This parameter specifies the message that is sent to the BlackBerry Connect app.                 |

## Example code

The following example sends a request to BEMS to move a contact to a different group in the contacts list.

```
{
  "method": "MoveContact",
  "params":
  {
    "contactIds": "user1@example.com",
    "fromGrouId": "2",
    "toGroupId": "1"
  },
  "id": "c58",
  "jsonrpc": "2.0"
}
```

If the request is successful, BEMS sends the following response to the BlackBerry Connect app and processes the request.

```
{
  "id": "c58",
  "error": null,
  "result":
  {
    "data":
    {
      "method": "MoveContact",
      "state": "PROCESSING"
    }
  },
  "jsonrpc": "2.0",
  "background": false
}
```

If there are no errors, BEMS sends the following notification to the BlackBerry Connect app and the contact is moved to the specified group.

```
{
  "id": "c58",
  "sequence": 1018547700000027,
  "result":
  {
    "data":
    {
      "method": "MoveContact",
      "state": "COMPLETE"
    }
  },
  "jsonrpc": "2.0",
}
```

## METHOD\_NotifyBackground

This method informs BEMS that the BlackBerry Connect app is in the background or the foreground.

The following table describes the parameters that you can include in this method.

| Parameter          | Type    | Required | Description  |
|--------------------|---------|----------|--|
| isBackgroundMode   | Boolean | ✓        | This parameter specifies that the BlackBerry Connect app is in the background or exited from the background. <ul style="list-style-type: none"> <li>If this value is true, BEMS is notified that the BlackBerry Connect app is in the background.</li> <li>If this value is false, BEMS is notified that the BlackBerry Connect app is in the foreground.</li> </ul> |
| timeout            | Integer | ✓        | This parameter specifies the duration to wait before going to the background or foreground. The default timeout value is in seconds.   |
| unreadMessageCount | Integer | —        | This parameter specifies the number of unread instant messages.  |
| dependencies       | String  | —        | This parameter specifies the other methods that this method is dependent on. It specifies the comma delimited dependent request ids.   |
| reconnect          | String  | —        | This parameter specifies that the BlackBerry Connect app re-establish the existing session. For example, if BlackBerry Connect goes to the background, when it comes to the foreground the same session is continued.  |
| pushType           | String  | —        | This parameter specifies one of the five push types. <ul style="list-style-type: none"> <li>Unknown = 0</li> <li>None = 1</li> <li>Default = 2</li> <li>Sender = 3</li> <li>SenderandMessage = 4</li> </ul>  |
| pushMaxLength      | Integer | —        | This parameter specifies the maxPayloadSize for the notification (for example, the FCM or APNS notifications).   |

**Note:** The notification message for this request might include the prior value because BEMS can send a response before processing the request.

### BEMS response and notification

The following table describes the parameters that BEMS returns and the notification that is sent to the BlackBerry Connect app when the app is in the background.

| Parameter | Type   | Description  |
|-----------|--------|--|
| state     | String | This parameter specifies the state of the request to BEMS (for example, Processing or Complete). |
| method    | String | This parameter specifies the method invocation name (for example, NotifyBackground).             |



## Example code

The following example sends a request to BEMS to notify it that the BlackBerry Connect app is in the background.

```
{
  "params":
  {
    "isBackgroundMode": "true",
    "unreadMessageCount": "50",
    "pushMaxLength": "0",
    "pushType": "4",
    "timeout": "5"
  },
  "id": "c3",
  "method": "NotifyBackground",
  "jsonrpc": "2.0"
}
```

If the request is successful, BEMS sends the following response to the BlackBerry Connect app and processes the request.

```
{
  "id": "C3",
  "error": null,
  "result":
  {
    "data":
    {
      "method": "NotifyBackground",
      "state": "PROCESSING"
    }
  },
  "jsonrpc": "2.0",
  "background": true
}
```

If there are no errors, BEMS sends the following notification to the BlackBerry Connect app when the app goes to the background.

```
{
  "id": "C3",
  "sequence": 1018536800000019,
  "result":
  {
    "data":
    {
      "method": "NotifyBackground",
      "state": "COMPLETE"
    }
  },
  "jsonrpc": "2.0"
}
```

## METHOD\_Ping

This method reports the state and status of BEMS.

The following table describes the parameters that you can include in this method.

| Parameter    | Type   | Required | Description   |
|--------------|--------|----------|---|
| dependencies | String | –        | This parameter specifies other methods that this method is dependent on. It specifies the comma delimited dependent request IDs.  |
| reconnect    | String | –        | This parameter specifies that the BlackBerry Connect app re-establish the existing session. For example, if BlackBerry Connect goes to the background, when it comes to the foreground the same session is continued. |

### BEMS response and notification

The following table describes the parameters that BEMS returns and the notification that is sent to the BlackBerry Connect app when it receives a request for its state and status.

| Parameter      | Type    | Description   |
|----------------|---------|---|
| method         | String  | This parameter specifies the method invoked (for example, Ping).  |
| state          | String  | This parameter specifies the state of the request to BEMS (for example, Processing or Complete).  |
| sessionTimeout | Integer | This parameter specifies the time when the when the session times out. By default, the sessionTimeout is set to 86400 seconds (24 hours). |

### Example code

The following example sends a request to BEMS to send its state and statistic information.

```
{
  "method": "Ping",
  "params": {},
  "id": "c58",
  "jsonrpc": "2.0"
}
```

If the request is successful, BEMS sends the following response to the BlackBerry Connect app and processes the request.

```
{
  "id": "c58",
  "error": null,
  "result": {
    "data": {
      "sessionTimeout": 86400,
      "method": "Ping",
      "state": "PROCESSING"
    }
  }
}
```

```

    },
    "jsonrpc": "2.0",
    "background": false
  }

```

If there are no errors, BEMS sends the following notification of the BEMS state and statistics.

```

{
  "id": "c58",
  "sequence": 1018682300000045,
  "result":
  {
    "data":
    {
      "sessionTimeout": 86400,
      "method": "Ping",
      "state": "COMPLETE"
    }
  },
  "jsonrpc": "2.0",
}

```

## METHOD\_ReceiveFile

This method receives a file from the sender in a one-to-one chat.

The following features are not supported:

- Resumable downloads

The following table lists the parameters that you can include in this method.

| Parameter   | Type   | Required | Description   |
|-------------|--------|----------|---|
| chatId      | String | ✓        | This parameter specifies the ID of the chat from which to download the file.                |
| fileId      | String | ✓        | This parameter specifies the file ID created by the BlackBerry Connect client for the file. |
| fileName    | String | ✓        | This parameter specifies the name of the file to send.                                      |
| fileSize    | Long   | ✓        | This parameter specifies the size of the file to send.                                      |
| percentDone | Number | ✓        | This parameter provides the percentage of the file that is downloaded to BEMS.              |

### Code example

The following example sends a request to BEMS for the recipient to receive the file from the one-to-one chat.

```

REST call URL: https://SERVER:8080/GaslampService/file/im/Contact-ID/FILE-NAME/
FileSize?fileId=FILE-REQUEST-ID
Verb: GET

```

```
HEADERS:
Cookie:sessionId=...
Accept:application/json
X-User-Agent:<iOS or Android>
```

If the request is successful, BEMS sends the following response. The response body is the file contents.

```
HTTP/1.1 200 OK
```

The following example sends a request to BEMS that the recipient receives a file from "user1" in the chat.

```
{
  "method": "ReceiveFile",
  "params":
  {
    "contactId": "user1@example.com",
    "fileName": "MyFile.txt",
    "fileSize": 1000000
  },
  "id": "c5",
  "jsonrpc": "2.0"
}
```

BEMS sends the following notification to the BlackBerry Connect app to receive the file. The file receive states are Processing > Progress > Complete. The receive includes a percentage of the file received that has completed.

```
{
  "id": "c5",
  "error": null,
  "result":
  {
    State: PROGRESS
    "data":
    {
      "method": "METHOD_ReceiveFile",
      "fileName": "MyFile.txt",
      "percentDone": "75"
    }
  },
  "jsonrpc": "2.0"
}
```

## METHOD\_RegisterTempRemotePresence

This method sends a registration request to BEMS to receive a remote user's presence status changes.

The following table describes the parameters that you can include in this method.

| Parameter    | Type   | Description  |
|--------------|--------|--|
| contactId    | String | This parameter specifies the contact ID of the user to register for the presence status changes.<br><br><b>Note:</b> The registration subscription persists until the user is unregistered (for example, UnRegisterTempRemotePresence) or the session times out. The user can be outside of the conversation list. |
| dependencies | String | This parameter specifies the other methods that this method is dependent on. It specifies the comma delimited dependent request IDs.   |
| reconnect    | String | This parameter specifies that the BlackBerry Connect app re-establish the existing session. For example, if BlackBerry Connect goes to the background, when it comes to the foreground the same session is continued.  |

### BEMS response and notification

The following table describes the parameters that BEMS returns and the notification to send to the BlackBerry Connect app when a contact registers for the presence status.

| Parameter | Type   | Description  |
|-----------|--------|--|
| method    | String | This parameter specifies the method invoked (for example, GetContactPhotos).                     |
| state     | String | This parameter specifies the state of the request to BEMS (for example, Processing or complete). |

### Example code

The following code example sends a request to BEMS to obtain a user's presence status.

```
{
  "method": "RegisterTempRemotePresence",
  "params":
    {
      "contactId": "sip:user_1@example.com"
    },
  "id": "c58",
  "jsonrpc": "2.0"
}
```

If the request is successful, BEMS sends the following response to the BlackBerry Connect app and processes the request.

```
{
  "id": "c58",
  "error": null,
  "result":
    {
      "data":
        {
```

```

        "method": "RegisterTempRemotePresence",
        "state": "PROCESSING"
    }
},
"jsonrpc": "2.0",
"background": false
}

```

If there are no errors, BEMS sends the following notification to the BlackBerry Connect app and displays the user's updated presence status.

```

{
  "id": "c58",
  "sequence": 1018691100000047,
  "result":
  {
    "data":
    {
      "method": "RegisterTempRemotePresence",
      "state": "COMPLETE"
    }
  },
  "jsonrpc": "2.0"
}

```

## METHOD\_RemoveContact

This method sends a request to BEMS to remove a contact from the user's BlackBerry Connect app contacts list. The following table describes the parameters that you can include in this method.

| Parameter    | Type   | Required | Description   |
|--------------|--------|----------|---|
| contactId    | String | ✓        | This parameter specifies the ID of the user to remove from the contact list.  |
| dependencies | String | —        | This parameter specifies the other methods that this method is dependent on. It specifies the comma delimited dependent request IDs.  |
| reconnect    | String | —        | This parameter specifies that the BlackBerry Connect app re-establish the existing session. For example, if BlackBerry Connect goes to the background, when it comes to the foreground the same session is continued. |

### BEMS response and notification

The following table describes the parameters that BEMS returns and the notification that is sent to the BlackBerry Connect app when a contact is removed from the user's contact list.

| Parameter | Type   | Description   |
|-----------|--------|---|
| method    | String | This parameter specifies the invoked method (for example, RemoveContact). |

| Parameter | Type   | Description  |
|-----------|--------|--|
| state     | String | This parameter specifies the state of the request to BEMS (for example, Processing or Complete). |

### Example code

The following example sends a request to BEMS to remove "user1" from the user's BlackBerry Connect app contact list.

```
{
  "method": "RemoveContact",
  "params":
  {
    "contactId": "sip:user1@example.com"
  },
  "id": "c14",
  "jsonrpc": "2.0"
}
```

If the request is successful, BEMS sends the following response to the BlackBerry Connect app and processes the request

```
{
  "id": "c14",
  "error": null,
  "result":
  {
    "data":
    {
      "method": "RemoveContact",
      "state": "PROCESSING"
    }
  },
  "jsonrpc": "2.0",
  "background": false
}
```

If there are no errors, BEMS sends the following notification to the BlackBerry Connect app and the contact is removed.

```
{
  "id": "c58",
  "sequence": 1018691100000047,
  "result":
  {
    "data":
    {
      "method": "RemoveContact",
      "state": "COMPLETE"
    }
  },
  "jsonrpc": "2.0"
}
```

## METHOD\_RemoveContactFromGroup

This method sends a request to BEMS to remove a contact from the user's a group.

The following table describes the parameters that you can include in this method.

| Parameter    | Type   | Required | Description   |
|--------------|--------|----------|---|
| contactId    | String | ✓        | This parameter specifies the ID of the contact to remove from the group.  |
| groupId      | String | —        | This parameter specifies the ID of the group from which the contact is to be removed from.  |
| dependencies | String | —        | This parameter specifies the other methods that this method is dependent on. It specifies the comma delimited dependent request ids.  |
| reconnect    | String | —        | This parameter specifies that the BlackBerry Connect app re-establish the existing session. For example, if BlackBerry Connect goes to the background, when it comes to the foreground the same session is continued. |

### BEMS response and notification

The following table describes the parameters that BEMS returns and the notification to send to the BlackBerry Connect app when a contact is removed from a group.

| Parameter | Type   | Description  |
|-----------|--------|--|
| method    | String | This parameter specifies the invoked method (for example, RemoveContactFromGroup).               |
| state     | String | This parameter specifies the state of the request to BEMS (for example, Processing or Complete). |
| message   | String | This parameter specifies the message that is sent to the BlackBerry Connect app.                 |

### Example code

The following example sends a request to BEMS to remove "user1" from a group.

```
{
  "method": "RemoveContactFromGroup",
  "params": {
    "contactId": "sip:user1@example.com",
    "groupId": "1"
  },
  "id": "c58",
  "jsonrpc": "2.0"
}
```



```
}
```

If the request is successful, BEMS sends the following response to the BlackBerry Connect app and processes the request.

```
{
  "id": "c58",
  "error": null,
  "result": {
    "data": {
      "method": "RemoveContactFromGroup",
      "state": "PROCESSING"
    }
  },
  "jsonrpc": "2.0",
  "background": false
}
```

If there are no errors, BEMS sends the following notification to the BlackBerry Connect app and the contact is removed from the group.

```
{
  "id": "c58",
  "sequence": 1018691400000048,
  "result": {
    "data": {
      "message": "Remove contact from group success.",
      "method": "RemoveContactFromGroup",
      "state": "COMPLETE"
    }
  },
  "jsonrpc": "2.0"
}
```

## METHOD\_RemoveGroup

This method sends a request to BEMS to remove a group from the user's contact list.

**Note:** To remove a group, contacts must be removed from the group first. If participants are still in the group, the user receives an error.

The following table describes the parameters that you can include in this method.

| Parameter    | Type   | Required | Description  |
|--------------|--------|----------|--|
| groupid      | String | ✓        | This parameter specifies the ID of the group to remove.  |
| dependencies | String | —        | This parameter specifies the other methods that this method is dependent on. It specifies the comma delimited dependent request IDs. |

| Parameter | Type   | Required | Description   |
|-----------|--------|----------|---|
| reconnect | String | –        | This parameter specifies that the BlackBerry Connect app re-establish the existing session. For example, if BlackBerry Connect goes to the background, when it comes to the foreground the same session is continued. |

### BEMS response and notification

The following table describes the parameters that BEMS returns and the notification that is sent to the BlackBerry Connect app when a group is removed from the contact list.

| Parameter | Type   | Description  |
|-----------|--------|--|
| method    | String | This parameter specifies the invoked method (for example, RemoveGroup).                          |
| state     | String | This parameter specifies the state of the request to BEMS (for example, Processing or Complete). |
| message   | String | This parameter specifies the message that is sent to the BlackBerry Connect app.                 |

### Example code

The following example sends a request to BEMS to remove a group from the user's BlackBerry Connect app contact list.

```
{
  "method": "RemoveGroup",
  "params": {
    "groupId": "1"
  },
  "id": "c14",
  "jsonrpc": "2.0"
}
```

If the request is successful, BEMS sends the following response to the BlackBerry Connect app and processes the request.

```
{
  "id": "c14",
  "error": null,
  "result": {
    "data": {
      "method": "RemoveGroup",
      "state": "PROCESSING"
    }
  },
  "jsonrpc": "2.0",
  "background": false
}
```

```
}
```

If there are no errors, BEMS sends the following notification to the BlackBerry Connect app and the group is removed.

```
{
  "id": "c58",
  "sequence": 1018691700000049,
  "result": {
    "data": {
      "method": "RemoveGroup",
      "state": "COMPLETE"
    }
  },
  "jsonrpc": "2.0"
}
```

## METHOD\_RenameGroup

This method sends a request to BEMS to rename a group in the user's contact list.

The following table describes the parameters that you can include in this method.

| Parameter    | Type   | Required | Description   |
|--------------|--------|----------|---|
| groupId      | String | ✓        | This parameter specifies the ID of the group to rename.   |
| newGroupName | String | ✓        | This parameter specifies the new name of the group.   |
| dependencies | String | —        | This parameter specifies the other methods that this method is dependent on. It specifies the comma delimited dependent request IDs.  |
| reconnect    | String | —        | This parameter specifies that the BlackBerry Connect app re-establish the existing session. For example, if BlackBerry Connect goes to the background, when it comes to the foreground the same session is continued. |

### BEMS response and notification

The following table describes the parameters that BEMS returns and the notification that is sent to the BlackBerry Connect app when a group is renamed.

| Parameter | Type   | Description  |
|-----------|--------|--|
| method    | String | This parameter specifies the invoked method (for example, RenameGroup).                          |
| state     | String | This parameter specifies the state of the request to BEMS (for example, Processing or Complete). |

| Parameter | Type   | Description  |
|-----------|--------|--|
| message   | String | This parameter specifies the message that is sent to the BlackBerry Connect app. |

### Example code

The following example sends a request to BEMS to rename a group to "Team building - summer" in the user's BlackBerry Connect app contact list.

```
{
  "method": "RenameGroup",
  "params":
  {
    "groupId": "1",
    "newGroupName": "Team building-summer"
  },
  "id": "c14",
  "jsonrpc": "2.0"
}
```

If the request is successful, BEMS sends the following response to the BlackBerry Connect app and processes.

```
{
  "id": "c14",
  "error": null,
  "result":
  {
    "data":
    {
      "method": "RenameGroup",
      "state": "PROCESSING"
    }
  },
  "jsonrpc": "2.0",
  "background": false
}
```

If there are no errors, BEMS sends the following notification to the BlackBerry Connect app and the group is renamed.

```
{
  "id": "c14",
  "sequence": 1018694700000051,
  "result":
  {
    "data":
    {
      "message": "Group rename Team building finished.",
      "method": "RenameGroup",
      "state": "COMPLETE"
    }
  },
  "jsonrpc": "2.0"
}
```

## METHOD\_ScheduleNotification

This method enables a BlackBerry Connect client session to schedule a silent notification that is sent to a client at a scheduled time to process when the client is in the background. This notification allows the client to respond when it receives a remote notification (for example, a wakeup call to maintain session keepalive or a notification prior to the Windows access token expiration). This method is not supported for GNP notifications.

The following table describes the parameters that you can include in this method.

| Parameter  | Type                   | Required | Description  |
|------------|------------------------|----------|--|
| scheduleAt | Integer                | ✓        | This parameter specifies the server relative time when the ScheduleNotification is sent to the client (for example, UTC ms since 1970/01/01).  |
| tag        | String                 | ✓        | This parameter is a client specified value that indicates the type of notification. The client can schedule multiple notifications, but each notification must have unique tags. Use descriptive names for the tags. For example, <ul style="list-style-type: none"><li>• Use windows_access_token_refresh when scheduling a notification to refresh a token.</li><li>• Use session_keepalive when scheduling a notification to ping BEMS to keep the session alive.</li></ul> |
| clientData | json dictionary object | —        | This optional parameter is a json dictionary object, that when it is available, is included in the notification payload request to BEMS.<br><b>Note:</b> For Android devices, the FCM format allows string values within the data. The client string encodes the clientData when it sends the request to BEMS.   |

### Code sample

The following example sends a request to BEMS to schedule a notification that is sent to the BlackBerry Connect app at a specified time.

```
{
  "id": "c3"
  "method": "ScheduleNotification",
  "params":
  {
    "scheduleAt": "1551522681",
    "tag": "session_keepalive",
    "clientData":
    {
      "task1": "wake up",
      "task2": "keep session alive"
    }
  },
  "jsonrpc": "2.0"
}
```

If there are no errors, BEMS sends the following confirmation to the BlackBerry Connect app to schedule the notification.

```
{
  "id": "c3",
  "error": "null",
  "result": {
    "data": {
      "method": "ScheduleNotification",
      "state": "COMPLETE"
    }
  },
  "jsonrpc": "2.0"
}
```

At the scheduled time, BEMS sends a silent notification to the BlackBerry Connect app as requested.

- On an iOS device,

```
{
  "aps": {
    content-available = 1
  }
  "custom": {
    "ts": "1551522681",
    "tag": "session_keepalive",
    "clientData": {
      "task1": "wake up",
      "task2": "keep session alive"
    }
  },
  "jsonrpc": "2.0"
}
```

- On an Android device,

```
"data": {
  "params": {
    "scheduleAt": "1551522681",
    "tag": "session_keepalive",
    "clientData": {
      "task1": "wake up",
      "task2": "keep session alive"
    }
  },
  "jsonrpc": "2.0"
}
```

## METHOD\_SearchDirectory

Use this method to search for contacts in a supported directory service (for example, Microsoft Active Directory and Directory Access).

The following table describes the parameters that you can include in this method.

| Parameter    | Type   | Required | Description  |
|--------------|--------|----------|--|
| keySearch    | String | ✓        | This parameter specifies the search term in the query.   |
| typeSearch   | String | ✓        | This parameter specifies the field to search (for example, first name, last name, display name, and email address).                  |
| dependencies | String | —        | This parameter specifies the other methods that this method is dependent on. It specifies the comma delimited dependent request IDs. |

### BEMS response and notification

The following table describes the parameters that BEMS returns and the notification to send to the BlackBerry Connect app when the user searches a directory for contacts.

| Parameter     | Type    | Description  |
|---------------|---------|--|
| method        | String  | This parameter specifies the invoked method (for example, SearchDirectory).                      |
| state         | String  | This parameter specifies the state of the request to BEMS (for example, Processing or Complete). |
| contacts      | Object  | This parameter displays the contact details of the returned contacts.                            |
| maxResults    | Integer | This parameter lists the number of contacts that match the directory search query.               |
| totalResolved | Integer | This parameter specifies the number of contacts that are returned for the search query.          |
| searchTerm    | String  | This parameter is the search term by which the directory is queried.                             |

### Code example

The following example sends a request to BEMS to search the directory for all contacts that have the letters "sa" included in their name.

```
{
  "id": "c5",
  "method": "DirectorySearch",
  "params": {
    "keySearch": "sa",
    "typeSearch": "name"
  },
  "jsonrpc": "2.0"
}
```

If the search request is successful, BEMS sends the following response to the BlackBerry Connect app.

```
{
  "id": "c5",
  "error": null,
  "result":
  {
    "data":
    {
      "method": "SearchDirectory",
      "state": "PROCESSING"
    }
  },
  "jsonrpc": "2.0",
  "background": true
}
```

If there are no errors, BEMS sends the following notification to the BlackBerry Connect app and displays the contacts that match the search query.

```
{
  "id": "c19",
  "sequence": 1018538100000020,
  "result":
  {
    "data":
    {
      "contacts":
      {
        "sip:useram9@example.com":
        {
          "uri": "sip:usersam9@example.com",
          "email": "usersam9@example.com",
          "personalMessage": "",
          "displayName": "user 9",
          "title": "",
          "workPhone": "",
          "mobilePhone": "",
          "availability": "-2",
          "presence": "No BEMS-Connect Presence",
          "isAllowedToShowPhoto": false,
          "photoHash": "PENDING",
          "groups": [],
          "containerId": "0",
          "container": "default",
          "type": "self",
          "numDevices": "1"
        }
      }
    },
    "maxResults": "50",
    "totalResolved": "50",
    "searchTerm": "sa",
    "method": "SearchDirectory",
    "state": "COMPLETE"
  }
}
```



## METHOD\_SendFile

This method sends a file to the recipient in a one-to-one chat.

The following table lists the parameters that you can include in this method.

| Parameter    | Type   | Required | Description  |
|--------------|--------|----------|--|
| contactId    | String | ✓        | This parameter specifies the ID of the contact that sends the file.<br><b>Note:</b> For the first message, BEMS generates a StartChat method to invite the contact to accept or decline a chat. For more information, see <a href="#">METHOD_StartChat</a> . |
| fileName     | String | ✓        | This parameter specifies the name of the file to send.   |
| fileSize     | Long   | ✓        | This parameter specifies the size of the file to send.   |
| dependencies | String | –        | This parameter specifies the other methods that this method is dependent on. It specifies the comma delimited dependent request IDs.   |
| percentDone  | Number | ✓        | This parameter provides the percentage of the file that is downloaded to BEMS.   |

### BEMS response and notification

The following table describes the parameters that BEMS returns and the notification sent to the BlackBerry Connect app when a file is sent in the chat.

| Parameter | Type   | Description   |
|-----------|--------|---|
| chatId    | String | This parameter specifies the ID of the chat to send the file to.  |
| timestamp | State  | This parameter specifies the date that the file was sent. The timestamp is in Epoch UTC Unix timestamp. |
| method    | String | This parameter specifies the invoked method (for example, SendFile).                                    |

### Code example

The following example sends a request to BEMS for the recipient to receive the file from the one-to-one chat.

```
REST call URL:https://SERVER:8080/GaslampService/file/im/Contact-ID/FILE-NAME/  
FileSize?fileId=FILE-REQUEST-ID  
Verb:PUT  
HEADERS:  
Cookie:sessionId=...  
Accept:application/json  
X-User-Agent:<iOS or Android>
```

If the request is successful, BEMS sends the following response. The response body is the file contents.

```
HTTP/1.1 200 OK
```

BEMS sends the following notification to the BlackBerry Connect app to send the file. The send file states are Processing > Progress > Complete. The send includes a percentage of the file sent that has completed.

```
{
  "id": "S11595",
  "sequence": 1118327100011764,
  "result": {
    "data": {
      "file": "MyFile.txt",
      "state": "PROGRESS",
      "fileRequestId": "d951ee49",
      "percentDone": 91,
      "method": "SendFile"
    }
  },
  "jsonrpc": "2.0"
}
```

## METHOD\_SendMessage

This method sends an instant message to a recipient.

The following table describes the parameters that you can include in this method.

| Parameter    | Type   | Required | Description  |
|--------------|--------|----------|--|
| contactId    | String | ✓        | This parameter specifies the ID of the recipient to send the message to.   |
| message      | String | ✓        | This parameter specifies the message to send.  |
| messageId    | String | ✓        | This parameter specifies the ID of the message created in the BlackBerry Connect app.  |
| dependencies | String | —        | This parameter specifies the other methods that this method is dependent on. It specifies the comma delimited dependent request IDs. |

### BEMS response and notification

The following table describes the parameters that BEMS returns and the notification to send to the BlackBerry Connect app when the user sends an instant message.

| Parameter | Type   | Description  |
|-----------|--------|--|
| timestamp | Sate   | This parameter specifies the date that the instant message was sent. The timestamp is in Epoch UTC Unix timestamp.   |
| method    | String | This parameter specifies the invoked method (for example, SendMessage).  |
| state     | String | This parameter specifies the state of the request to BEMS (for example, Processing or Complete).   |
| chatId    | String | This parameter specifies the ID of the chat to send the message to.<br><b>Note:</b> For the first message, the BEMS generates a StartChat to invite the contact to accept or decline a chat. |

### Code sample

The following code example sends a request to BEMS to send a message to "user1".

```
{
  "method": "SendMessage",
  "params":
  {
    "contactId": "user1@example.com",
    "message": "Are you there?",
    "messageId": "125988FKKFJFHI2345"
  },
  "id": "c5",
  "jsonrpc": "2.0"
}
```

If the request is successful, BEMS sends the following response to the BlackBerry Connect app and processes the request.

```
{
  "id": "c5",
  "error": null,
  "result":
  {
    "data":
    {
      "timestamp": "189238873498795",
      "method": "SendMessage",
      "state": "PROCESSING"
    }
  },
  "jsonrpc": "2.0",
  "background": false
}
```

If there are no errors, BEMS sends the following notification and sends the message to the recipient.

```
{
  "id": "c5",
  "sequence": 1018532000000017,
  "result":
```

```

{
  "data":
  {
    "timestamp": "189238873498795",
    "chatId": "78bb705f-230a-45ad-9654-651f906621e1",
    "method": "SendMessage",
    "state": "COMPLETE"
  }
},
"jsonrpc": "2.0"
}

```

If the message times out or recipient declines the invitation, BEMS sends a MessageUpdate notification to the BlackBerry Connect app.

- Sample notification if the invitation times out.

```

{
  "id": "s50",
  "error":
  {
    "data":
    {
      "type": "ack",
      "status": "timeout",
      "contactIds": [sip:user1@example.com],
      "messageId": "125988FKKFJFHI2345",
      "method": "MessageUpdate"
    }
  },
  "jsonrpc": "2.0"
}

```

- Sample notification if the recipient declines the invitation.

```

{
  "id": "s50",
  "error":
  {
    "data":
    {
      "type": "declined",
      "status": "terminated",
      "contactIds": [sip:user1@example.com],
      "messageId": "125988FKKFJFHI2345",
      "method": "MessageUpdate"
    }
  },
  "jsonrpc": "2.0"
}

```

## METHOD\_SetGDAuthToken

This method submits a request from the BlackBerry Connect app to BEMS to update the gdAuthToken associated with an instant messaging session.

| Parameter   | Type   | Required | Description   |
|-------------|--------|----------|---|
| gdAuthToken | String | ✓        | This parameter specifies the value of the BlackBerry Dynamics authToken. The BEMS-Connect server confirms the validity of the token with the BlackBerry Proxy server and uses the identity in the BlackBerry Dynamics AuthToken as the user ID. The user ID must match the identity in the session. |

No notification is sent from BEMS as this method succeeds or fails synchronously.

## METHOD\_SetGDToken

Use this method to set the BlackBerry Dynamics access token.

The following table describes the parameters that you can include in this method.

| Parameter  | Type   | Required | Description   |
|--|--------|----------|---|
| gdToken<br>* Use this parameter if you are using the API version 2.2 or earlier. | String | ✓        | This parameter specifies the BlackBerry Dynamics token that the BlackBerry Connect app retrieves from Good Proxy and presents it to BEMS for authentication.  |
| dependencies   | String | —        | This parameter specifies the other methods that this method is dependent on. It specifies the comma delimited dependent request IDs.  |
| reconnect  | String | —        | This parameter specifies that the BlackBerry Connect app re-establish the existing session. For example, if BlackBerry Connect goes to the background and returns to the foreground, the same session is continued. |

### BEMS response and notification

The following table describes the parameters that BEMS returns and the notification that is sent to the BlackBerry Connect app when a token is set.

| Parameter | Type   | Description  |
|-----------|--------|--|
| method    | String | This parameter returns the invoked method (for example, SetGDToken).                             |
| state     | String | This parameter specifies the state of the request to BEMS (for example, Processing or Complete). |

## Code example

The following example sends a request to BEMS to begin an instant messaging chat session.

```
{
  "id": "c112",
  "method": "SetGDToken",
  "params":
  {
    "SetGDToken": "d64a57b7-f5b5-4e3a-839b-00618653a090"
  },
  "jsonrpc": "2.0"
}
```

If the request is successful, BEMS sends the following response and token to the BlackBerry Connect app.

```
{
  "id": "c112",
  "method": "SetGDToken",
  "result":
  {
    "status": "success"
  },
  "state": "COMPLETE"
  "jsonrpc": "2.0"
}
```

## METHOD\_SetGNPToken

This method is related to the BlackBerry Dynamics push notifications. The BlackBerry Dynamics push notifications requires that the BlackBerry Connect app retrieves a token assigned by the BlackBerry Proxy server. The token is passed to the BEMS-Connect server, which sends the push notifications.

The following table describes the parameters that you can include in this method.

| Parameter | Type   | Required | Description   |
|-----------|--------|----------|---|
| gnpToken  | String | ✓        | This parameter specifies the value of the GNP token. The BlackBerry Connect app retrieves the token from the BlackBerry Dynamics client API and sends it to the BEMS-Connect server for use in push notifications. The BEMS-Connect server confirms the validity of the token with the BlackBerry Proxy server. |

## METHOD\_SetOAuth2Token

This method sends a request to BEMS requesting a new token when a previous token that was sent through the [METHOD\\_BeginSession](#) expired.

The following table describes the parameters that you can include in this method.

| Parameter   | Type   | Required | Description   |
|-------------|--------|----------|---|
| oAuth2Token | String | ✓        | This parameter specifies the new token that is created. |

### BEMS response and notification

The following table describes the parameters that BEMS returns and the notification sent to the BlackBerry Connect app when a chat session is started.

| Parameter | Type   | Description  |
|-----------|--------|--|
| method    | String | Returns the invoked method (for example, BeginSession).  |
| state     | String | This parameter specifies the state of the request to BEMS (for example, Processing or Complete). |
| sessionid | String | This parameter specifies the session ID for the user.  |

### Code example

The following example sends a request to BEMS to generate a new access token.

```
{
  "id": "c12",
  "method": "SetOAuth2Token",
  "params": {
    "oAuth2Token": "cwt=AAEBHAEFAAAAAAAFFQAAADtSBd...gNEA-id-_ZgS9ZvC"
  },
  "jsonrpc": "2.0"
}
```

If the request is successful, BEMS sends the following response and token to the BlackBerry Connect app.

```
{
  "id": "c13",
  "method": "SetOAuth2Token",
  "result": {
    "status": "success"
  },
  "state": "COMPLETE"
  "jsonrpc": "2.0"
}
```

## METHOD\_SetPersonalMessage

This method sets the personal message for the user. Microsoft refers to this method as 'status'.

The following table describes the parameters that you can include in this method.

| Parameter             | Type   | Required | Description   |
|-----------------------|--------|----------|---|
| personalMessageString |        | ✓        | This parameter specifies the user's personal message (for example, I am in a meeting).  |
| dependencies          | String | —        | This parameter specifies the other methods that this method is dependent on. It specifies the comma delimited dependent request ids.  |
| reconnect             | String | —        | This parameter specifies that the BlackBerry Connect app re-establish the existing session. For example, if BlackBerry Connect goes to the background, when it comes to the foreground the same session is continued. |

### BEMS response and notification

The following table describes the parameters that BEMS returns and the notification to send to the BlackBerry Connect app when the user sets a personal message.

| Parameter | Type   | Description  |
|-----------|--------|--|
| method    | String | This parameter specifies the invoked method (for example, SetPersonalMessage).                   |
| state     | String | This parameter specifies the state of the request to BEMS (for example, Processing or Complete). |

### Code example

The following example sends a request to BEMS to set the user's personal message.

```
{
  "id": "c12",
  "method": "SetPersonalMessage",
  "params":
  {
    "personalMessage": "I am in a meeting"
  },
  "jsonrpc": "2.0"
}
```

If the request is successful, BEMS returns the following response to the BlackBerry Connect app and processes the request.

```
{
  "id": "c12",
  "error": null,
  "result":
  {
    "data": ,
    {
      "method": "SetPersonalMessage",
      "state": "PROCESSING"
    }
  }
}
```



```

    }
  },
  "jsonrpc": "2.0"
  "background": false
}

```

If there are no errors, BEMS sends the following notification to the BlackBerry Connect app and sets the personal message.

```

{
  "id": "c12",
  "sequence": 1018697800000053,
  "result":
  {
    "data":
    {
      "method": "SetPersonalMessage",
      "state": "COMPLETE"
    }
  },
  "jsonrpc": "2.0"
}

```

## METHOD\_SetPresence

This method sets the presence status for the user. This method is called 'status' by Microsoft.

| Parameter       | Type   | Required | Description   |
|-----------------|--------|----------|---|
| presence        | String | √        | This parameter specifies the user's presence (for example, available, busy, or away).   |
| personalMessage | String | —        | This parameter specifies the user's personal message (for example, I am in a meeting).  |
| dependencies    | String | —        | This parameter specifies the other methods that this method is dependent on. It specifies the comma delimited dependent request ids.  |
| reconnect       | String | —        | This parameter specifies that the BlackBerry Connect app re-establish the existing session. For example, if BlackBerry Connect goes to the background, when it comes to the foreground the same session is continued. |

### BEMS response and notification

The following table describes the parameters that BEMS returns and the notification to send to the BlackBerry Connect app when the user sets their presence status.

| Parameter | Type   | Description  |
|-----------|--------|--|
| method    | String | This parameter specifies the method that is invoked (for example, SetPresence or Complete).      |
| state     | String | This parameter specifies the state of the request to BEMS (for example, Processing or Complete). |

### Code sample

The following example sends a request to BEMS to set the user's presence and specify a personal message.

```
{
  "method": "SetPresence",
  "params":
  {
    "presence": "busy",
    "personalMessage": "I am in meeting",
  },
  "id": "c7",
  "jsonrpc": "2.0"
}
```

If the request is successful, BEMS sends the following response to the BlackBerry Connect app and processes the request.

```
{
  "id": "c7",
  "error": null,
  "result":
  {
    "data":
    {
      "method": "SetPresence",
      "state": "PROCESSING"
    }
  },
  "jsonrpc": "2.0",
  "background": false
}
```

If there are no errors, BEMS sends the following notification to the BlackBerry Connect app and displays the presence status and sets the personal message.

```
{
  "id": "c7",
  "sequence": 1018697900000054,
  "result":
  {
    "data":
    {
      "method": "SetPresence",
      "state": "COMPLETE"
    }
  },
  "jsonrpc": "2.0"
}
```

```
}
```

## METHOD\_StartChat

This method sends a chat request with another user to BEMS.

The following table describes the parameters that you can include in this method.

| Parameter    | Type   | Required | Description   |
|--------------|--------|----------|---|
| contactId    | String | ✓        | This parameter specifies a unique ID for the recipient to start a chat with.  |
| dependencies | String | —        | This parameter specifies the other methods that this method is dependent on. It specifies the comma delimited dependent request IDs.  |
| reconnect    | String | —        | This parameter specifies that the BlackBerry Connect app re-establish the existing session. For example, if BlackBerry Connect goes to the background, when it comes to the foreground the same session is continued. |

### BEMS response and notification

The following table describes the parameters that BEMS returns and the notification to send to the BlackBerry Connect app when the user invites a contact to a chat session.

| Parameter  | Type   | Description  |
|------------|--------|--|
| timestamp  | Date   | This parameter specifies the date that the message was sent. The timestamp is in Epoch UTC Unix timestamp. |
| method     | String | This parameter specifies the invoked method (for example, StartChat).                                      |
| state      | String | This parameter specifies the state of the request to BEMS (for example, Processing or Complete).           |
| requestIds | String | This parameter specifies the unique identifier for the contact to start a chat with.                       |

### Code sample

The following example sends a notification to BEMS that the user wants to start a chat with "User1".

```
{
  "method": "StartChat",
  "params":
  {
    "contactId": "sip:user1@example.com",
  },
  "jsonrpc": "2.0",
  "id": "c12",
```

```
}
```

If the request is successful, BEMS sends the following response to the BlackBerry Connect app and processes the request.

```
{
  "id": "c12",
  "error": null,
  "result": {
    "data": {
      "timestamp": 1557918101769,
      "method": "StartChat",
      "state": "PROCESSING"
    }
  },
  "jsonrpc": "2.0",
  "background": false
}
```

If there are no errors, BEMS sends the following notification to the BlackBerry Connect app and the user starts the chat with the recipient.

```
{
  "id": "S38",
  "sequence": 1018698100000057,
  "result": {
    "data": {
      "requestIds": {
        "5524d5c3-cf6a-4bf1-ac41-5eaa5da0d043": {
          "contactId": "sip:user1@example.com",
          "displayName": "1 User",
          "requestId": "5524d5c3-cf6a-4bf1-ac41-5eaa5da0d043",
          "timestamp": 1557918102256,
          "message": "",
          "status": "Active",
          "reason": "Incoming"
        }
      }
    },
    "method": "StartChat",
    "state": "COMPLETE"
  }
},
"jsonrpc": "2.0"
}
```

## METHOD\_StartTyping

This method sends a notification to BEMS that the user is typing a message in the chat.

The following table describes the parameters that you can include in this method.

| Parameter    | Type   | Required | Description   |
|--------------|--------|----------|---|
| contactId    | String | ✓        | This parameter specifies the SIP address of the user that is typing the message.  |
| chatId       | String | ✓        | This parameter specifies the unique identifier for the chat session.  |
| dependencies | String | —        | This parameter specifies the other methods that this method is dependent on. It specifies the comma delimited dependent request IDs.  |
| reconnect    | String | —        | This parameter specifies that the BlackBerry Connect app re-establish the existing session. For example, if BlackBerry Connect goes to the background, when it comes to the foreground the same session is continued. |

The following table lists the message results based on the response for the contactId and chatId from the BlackBerry Connect app. You must have the correct chatId and contactId to send a message to the recipient successfully.

| contactId  | chatId     | Result                 |
|------------|------------|------------------------|
| correct    | correct    | Success                |
| correct    | in-correct | Success                |
| in-correct | correct    | Error message received |
| in-correct | in-correct | Error message received |

### BEMS response and notification

The following table describes the parameters that BEMS and the notification to send to the BlackBerry Connect app when the user starts typing in a chat session.

| Parameter | Type   | Description  |
|-----------|--------|--|
| method    | String | This parameter specifies the method invoked (for example, StartTyping).          |
| contactId | String | This parameter specifies the SIP address of the user that is typing the message. |

### Code sample

The following code example sends a notification to BEMS that the user is typing a message in a chat.

```
{
  "id": "c12",
  "method": "StartTyping",
  "params":
  {
    "contactId": "sip:user1@example.com",
```

```

    "chatId": "dbc2e7b6-25e8-450e-9670-c9e4f32341bb"
  },
  "jsonrpc": "2.0"
}

```

If the request is successful, BEMS sends the following response to the BlackBerry Connect app and processes the request.

```

{
  "id": "c12",
  "error": null,
  "result":
  {
    "data":
    {
      "method": "StartTyping",
      "state": "PROCESSING"
    }
  },
  "jsonrpc": "2.0",
  "background": false
}

```

If there are no errors, BEMS sends the following notification to the BlackBerry Connect app and the user types the message.

```

{
  "id": "c12",
  "sequence": 1018698700000065,
  "result":
  {
    "data":
    {
      "method": "StartTyping",
      "state": "COMPLETE"
    }
  },
  "jsonrpc": "2.0"
}

```

## METHOD\_StopTyping

This method sends a notification to BEMS when the user stopped typing a message in the chat.

The following table describes the parameters that you can include in this method.

| Parameter | Type   | Required | Description  |
|-----------|--------|----------|--|
| contactId | String | ✓        | This parameter specifies the sip address of the user that is typing the message. |
| chatId    | String | ✓        | This parameter specifies the unique identifier for the chat session.             |

| Parameter    | Type   | Required | Description   |
|--------------|--------|----------|---|
| dependencies | String | –        | This parameter specifies the other methods that this method is dependent on. It specifies the comma delimited dependent request IDs.  |
| reconnect    | String | –        | This parameter specifies that the BlackBerry Connect app re-establish the existing session. For example, if BlackBerry Connect goes to the background, when it comes to the foreground the same session is continued. |

### BEMS response and notification

The following table describes the parameters that BEMS returns and the notification to send to the BlackBerry Connect app when the user stops typing in the chat session.

| Parameter | Type   | Description  |
|-----------|--------|--|
| method    | String | This parameter specifies the method invoked (for example, StopTyping).                           |
| state     | String | This parameter specifies the state of the request to BEMS (for example, Processing or Complete). |

### Code sample

The following code example sends a notification to BEMS and the notification to send to the BlackBerry Connect app when the user stops typing a message.

```
{
  "id": "c12",
  "method": "StopTyping",
  "params": {
    "contactId": "user1@example.com",
    "chatId": "dbc2e7b6-25e8-450e-9670-c9e4f32341bb"
  },
  "jsonrpc": "2.0"
}
```

If the request is successful, BEMS sends the following response to the BlackBerry Connect app and processes the request.

```
{
  "id": "c12",
  "error": null,
  "result": {
    "data": {
      "method": "StopTyping",
      "state": "PROCESSING"
    }
  },
}
```

```
"jsonrpc": "2.0",
"background": false
}
```

If there are no errors, BEMS sends the following notification to the BlackBerry Connect app and the user stops typing the message.

```
{
  "id": "c12",
  "sequence": 1018698900000066,
  "result":
  {
    "data":
    {
      "method": "StopTyping",
      "state": "PROCESSING"
    }
  },
  "jsonrpc": "2.0",
}
```

## METHOD\_System.GetServerInfo

This method sends a request to BEMS to return the web socket URL on supported environments.

### BEMS response and notification

The following table describes the parameters that BEMS returns and the notification sent to the BlackBerry Connect app when a chat session is started.

| Parameter | Type   | Description  |
|-----------|--------|--|
| method    | String | Returns the invoked method (for example, System.GetServerInfo).                                  |
| state     | String | This parameter specifies the state of the request to BEMS (for example, Processing or Complete). |

### Code example

The following example sends a request to begin BEMS to return the web socket URL to the BlackBerry Connect app.

```
{
  "method": "System.GetServerInfo",
  "params":
  {
  },
  "id": "c1",
  "jsonrpc": "2.0"
}
```



If the request is successful, BEMS sends the following response to the BlackBerry Connect app and processes the request.

```

{
  "id": "c1",
  "error": null,
  "result":
  {
    "data":
    {
      "Build Version":"2.16.2.282.566401",
      "DB_SESSION_TIMEOUT_SECS":300,
      "SESSION_TIMEOUT_SECS":86400,
      "GD_URL": "<bems name>.example.com",
      "MAX_USERS_THRESHOLD":10000,
      "Connect Server Start Time":"Wednesday, June 5, 2019 1:04:23 PM",
      "Number of Sessions":0,
      "WebSocket URL":"wss://websocket.example.com:8082/GaslampService/ws",
      "method":"System.GetServerInfo",
      "state":"PROCESSING"
    }
  },
  "jsonrpc":"2.0"
}

```

## METHOD\_TerminateSession

This method sends a notification to BEMS that the user has ended the chat session or logged out of the BlackBerry Connect app.

The following table describes the parameters that you can include in this method.

| Parameter    | Type   | Required | Description   |
|--------------|--------|----------|---|
| dependencies | String | —        | This parameter specifies the other methods that this method is dependent on. It specifies the comma delimited dependent request IDs.  |
| reconnect    | String | —        | This parameter specifies that the BlackBerry Connect app re-establish the existing session. For example, if BlackBerry Connect goes to the background, when it comes to the foreground the same session is continued. |

### BEMS response and notification

The following table describes the parameters that BEMS that returns and the notification to send to the BlackBerry Connect app when the user ends a session.

| Parameter | Type   | Description  |
|-----------|--------|--|
| method    | String | This parameter specifies the invoked method (for example, TerminateSession). |

| Parameter | Type   | Description  |
|-----------|--------|--|
| state     | String | This parameter specifies the state of the request to BEMS (for example, Processing or Complete). |

### Code sample

The following example sends a notification to BEMS that the user is ending the chat session or logging out of the BlackBerry Connect app.

```
{
  "method": "TerminateSession",
  "params": {},
  "id": "c12",
  "jsonrpc": "2.0"
}
```

If the request is successful, BEMS sends the following response to the BlackBerry Connect app and processes the request.

```
{
  "id": "c12",
  "error": null,
  "result": {
    "data": {
      "method": "TerminateSession",
      "state": "COMPLETE"
    }
  },
  "jsonrpc": "2.0",
  "background": false
}
```

If there are no errors, BEMS sends the following notification to the BlackBerry Connect app and the user ends the chat session or logs out of the app.

```
{
  "id": "c12",
  "sequence": 1018699100000067,
  "result": {
    "data": {
      "method": "TerminateSession",
      "state": "COMPLETE"
    }
  },
  "jsonrpc": "2.0"
}
```

# METHOD\_UnblockContact

This method notifies BEMS that the user is unblocking a contact on the BlackBerry Connect app contacts list.

| Parameter    | Type   | Required | Description   |
|--------------|--------|----------|---|
| contactId    | String | ✓        | <p>This parameter specifies the ID of the user to unblock. Users can unblock other users that are a part of their contact list and users that are not a part of the contact list.</p> <p><b>Note:</b> When you unblock another user, the user that initiates the unblock starts to receive ContactUpdate notifications for the previously blocked user. If the user has other active sessions with the user blocked, they won't receive ContactUpdates for the user in those sessions. The user can get the blocked user's status by searching for their contact details.</p> |
| dependencies | String | —        | This parameter specifies the other methods that this method is dependent on. It specifies the comma delimited dependent request IDs.  |
| reconnect    | String | —        | This parameter specifies that the BlackBerry Connect app re-establish the existing session. For example, if BlackBerry Connect goes to the background, when it comes to the foreground the same session is continued.   |

## BEMS response and notification

The following table describes the parameters that BEMS returns and the notification to send to the BlackBerry Connect app when the user unblocks a contact in the contact list.

| Parameter | Type   | Description  |
|-----------|--------|--|
| method    | String | This parameter specifies the invoked method (for example, UnblockContact).                       |
| state     | String | This parameter specifies the state of the request to BEMS (for example, Processing or Complete). |

## Code example

The following code example sends a request to BEMS to unblock "user33" in the contact list.

```
{
  "id": "c12",
  "method": "UnblockContact",
  "params": {
    "contactIds": { "user33@example.com" }
  },
  "jsonrpc": "2.0"
}
```

If the request is successful, BEMS sends the following response to the BlackBerry Connect app and processes the request.

```
{
  "id": "c12",
  "error": null,
  "result": {
    "data": {
      "method": "UnblockContact",
      "state": "PROCESSING"
    }
  },
  "jsonrpc": "2.0",
  "background": false
}
```

If there are no errors, BEMS sends the following notification to the BlackBerry Connect app and the contact is unblocked.

```
{
  "id": "c12",
  "sequence": 1018699900000077,
  "result": {
    "data": {
      "method": "UnblockContact",
      "state": "COMPLETE"
    }
  },
  "jsonrpc": "2.0",
}
```

## METHOD\_UnRegisterTempRemotePresence

This method sends an unregister request to BEMS to stop receiving a remote user's presence status and container changes.

The following table describes the parameters that you can include in this method.

| Parameter    | Type   | Required | Description   |
|--------------|--------|----------|---|
| contactId    | String | ✓        | This parameter specifies the ID of the user to unregister.  |
| dependencies | String | —        | This parameter specifies the other methods that this method is dependent on. It specifies the comma delimited dependent request IDs.  |
| state        | String | —        | This parameter specifies that the BlackBerry Connect app re-establish the existing session. For example, if BlackBerry Connect goes to the background, when it comes to the foreground the same session is continued. |

## BEMS response and notification

The following table describes the body properties that BEMS returns and the notification to send to the BlackBerry Connect app when the user stops receiving a contact's presence status.

| Parameter | Type   | Description  |
|-----------|--------|--|
| method    | String | This parameter specifies the invoked method (for example, UnRegisterTempRemotePresenceSubscription). |
| state     | String | This parameter specifies the state of the request to BEMS (for example, Processing or Complete).     |
| message   | String | This parameter specifies the message that is sent to the BlackBerry Connect app.                     |

### Code example

The following example sends a request to BEMS to unregister "user33's" presence in the BlackBerry Connect app contact list.

```
{
  "method": "UnRegisterTempRemotePresenceSubscription",
  "params": {
    "contactIds": {"user33@example.com"}
  },
  "id": "c12",
  "jsonrpc": "2.0",
}
```

If the request is successful, BEMS sends the following response to the BlackBerry Connect app and processes the request.

```
{
  "id": "c12",
  "error": null,
  "result": {
    "data": {
      "method": "UnRegisterTempRemotePresenceSubscription",
      "state": "PROCESSING"
    }
  },
  "jsonrpc": "2.0",
  "background": false
}
```

If there are no errors, BEMS sends the following notification to the BlackBerry Connect app and the presence status is temporarily removed from the contact.

```
{
  "id": "c12",
  "sequence": 1018699900000077,
  "result": {
```

```
    "data":  
      {  
        "method": "UnRegisterTempRemotePresenceSubscription",  
        "state": "COMPLETE"  
      }  
    },  
    "jsonrpc": "2.0",  
  }  
}
```

## **METHOD\_UserUpdate**

Use this method to send a user update request to the server and retrieve the user's contact card.

# Administrative methods

This section provides information about APIs that complete administrative persistent chat tasks. The following administrative methods are available:

- [METHOD\\_PC\\_CreateRoom](#)
- [METHOD\\_PC\\_DisableRoom](#)
- [METHOD\\_PC\\_GetCategories](#)
- [METHOD\\_PC\\_GetRoom](#)
- [METHOD\\_PC\\_UpdateRoom](#)
- [METHOD\\_PC\\_UpdateRoomUsers](#)

## METHOD\_PC\_CreateRoom

This method creates a group discussion.

The following table describes the parameters that you can include in this method.

| Parameter   | Type         | Required | Description  |
|-------------|--------------|----------|--|
| name        | String       | ✓        | This parameter specifies the discussion group name. Discussion group names can be a maximum of 256 alphanumeric, numeric, special characters or a combination of these. This includes spaces.  |
| description | String       | —        | This parameter specifies a description of the group discussion and can be a maximum of 256 characters. This includes spaces.   |
| category    | String       | —        | This parameter specifies the ID of the category that the group discussion is placed under. If the category is not specified, a default category must be defined in the BEMS dashboard.<br><b>Note:</b> The user must be granted Creator role in the group discussion category to create group discussions.       |
| privacy     | String       | —        | This parameter specifies the security level of a group discussion.   |
| managers    | String Array | —        | This parameter specifies a list of users that can manage the group discussion. Each group discussion must have a minimum of one manager. Managers are automatically added as members to the group discussion.<br>Individual users and Active Directory user groups can be set as managers of a group discussion. |
| members     | String Array | —        | This parameter specifies a list of users that have joined the group discussion and can participate in and receive notifications.<br>Individual users and Active Directory user groups can be set as managers of a group discussion.  |

| Parameter       | Type    | Required | Description  |
|-----------------|---------|----------|--|
| skipInvitations | Boolean | –        | This parameter specifies if an invitation is sent. By default, this parameter is set to False. <ul style="list-style-type: none"> <li>If true, an invitation is not sent.</li> <li>If false, an invitation is inherited from the category parameter.</li> </ul>                          |
| follow          | Boolean | –        | This parameter specifies if a group discussion should be followed. By default, the follow parameter is false. <ul style="list-style-type: none"> <li>If true, the group discussion should be followed.</li> <li>If false, the group discussion isn't required to be followed.</li> </ul> |

### Notification

The following table describes the notifications that BEMS might send to the BlackBerry Connect app after it processes the request.

**Note:** Group discussion creation can succeed while other operations like setting group discussion members, managers and privacy setting can be unsuccessful. The METHOD\_PC\_CreateRoom API method returns success if the group discussion creation is successful. For more information about subsequent operations and error messages, see InnerError below.

| Parameter  | Type       | Description   |
|------------|------------|---|
| roomName   | String     | This parameter specifies the name of the group discussion.  |
| roomId     | String     | This parameter specifies the ID of the group discussion.  |
| innerError | Json Array | This parameter specifies an array of error messages that might occur when updating group discussion members, managers, and privacy settings. See InnerError below for more information. |

### InnerError

InnerError errors might occur when a method is multifunctional (for example, create room and automatically follow the room). The following errors might occur when updating members, managers, and privacy settings for a group discussion:

- Name of group discussion is used by another group discussion. Group discussions must be unique.
- The manager or member being added is not a valid instant messenger user.
- The manager or member specified is not allowed to be a manager or member as per the category specification.
- The user does not have permissions to create a group discussion in the category.

The following table describes the parameters that are included for innererrors.

| Parameter | Type   | Description                              |
|-----------|--------|--|
| type      | String | This parameter specifies the error type. |



| Parameter   | Type         | Description   |
|-------------|--------------|---|
| parameter   | String       | This parameter specifies the parameter name if the error is caused by an input parameter. This is optional. |
| errorValues | String Array | This parameter specifies a list of invalid values. This is optional.  |
| message     | String       | This parameter specifies the error message.   |

### Code example

The following example sends a request to BEMS to create a group discussion called 'Surprise retirement celebration' and include user1 and user2 as managers and user3 and user4 as members.

```
{
  "method": "pc.CreateRoom",
  "params":
  {
    "name": "Surprise retirement celebration",
    "managers": [ "sip:user1@example.com", "sip:user2@example.com" ],
    "members": [ "sip:user3@example.com", "sip:user4@example.com" ]
  },
  "id": "c5",
  "jsonrpc": "2.0"
}
```

If the request is successful, BEMS sends the following response to the BlackBerry Connect app and processes the request.

```
{
  "id": "c5",
  "error": null,
  "result":
  {
    "data":
    {
      "method": "pc.CreateRoom",
      "state": "PROCESSING"
    }
  },
  "jsonrpc": "2.0"
}
```

If there are no errors, BEMS sends the following notification to the BlackBerry Connect client and creates the group discussion and sends invitations to the contacts.

```
{
  "id": "c5",
  "sequence": 1018690500000007,
  "result":
  {
    "data":
    {
      "roomId": "ma-chan://gems.sw.rim.net/3346c2de-6cc7-4186-ad62-0e5e33b889ed",
      "roomName": "Room@15May2019",
      "method": "pc.CreateRoom",

```

```

        "state": "COMPLETE"
    }
},
"jsonrpc": "2.0"
},
{
    "id": "S12",
    "sequence": 1018690500000008,
    "result":
    {
        "data":
        {
            "numberOfParticipants": 0,
            "roomId": "ma-chan://gems.sw.rim.net/3346c2de-6cc7-4186-
ad62-0e5e33b889ed",
            "roomName": "Room@15May2019",
            "roomDescription": "",
            "invitationId": 52,
            "method": "pc.InvitationReceived",
            "state": "COMPLETE"
        }
    }
},
"jsonrpc": "2.0"
}

```

If error messages are returned, BEMS sends the following notification to the BlackBerry Connect client and the group discussion isn't created. In this example an error occurred when the updating the group and an incorrect privacy was specified.

```

{
    "id": "c5",
    "sequence": 1018690500000006,
    "result":
    {
        "data":
        {
            "method": "pc.CreateRoom",
            "roomName": "Surprise retirement celebration",
            "roomId": "ma-chan://gems.sw.rim.net/79b523a6-c78b-4cec-be33-4c2f14ce1438",
            "innerError": [
                {
                    "type": "updateError",
                    "message": "Error while updating room +[Exception Message]"
                },
                {
                    "type": "parameterError",
                    "parameter": "privacy",
                    "errorValues": ["public"],
                    "message": "Invalid room privacy +[Exception Message]"
                }
            ]
        }
    }
},
"jsonrpc": "2.0"
}

```

# METHOD\_PC\_DisableRoom

This method disables a group discussion. Only managers of a group discussion can disable the group discussion.

**Note:** When users disable a group discussion, only the persistent chat administrator can enable it again.

The following table describes the parameters that you can include in this method.

| Parameter | Type   | Required | Description   |
|-----------|--------|----------|---|
| roomId    | String | ✓        | This parameter specifies the ID of the group discussion to disable. |

## InnerError

The following errors might occur when disabling a group discussion:

- The group discussion identified by the group discussion ID doesn't exist.

## Code example

The following example sends a disable group discussion request to BEMS.

```
{
  "method": "pc.DisableRoom",
  "params":
  {
    "roomId": "ma-chan://gems.sw.rim.net/79b523a6-c78b-4cec-be33-4c2f14ce1438"
  },
  "id": "c5",
  "jsonrpc": "2.0"
}
```

If the request is successful, BEMS sends the following response to the BlackBerry Connect app and processes the request

```
{
  "id": "c5",
  "error": null,
  "result":
  {
    "data":
    {
      "method": "pc.DisableRoom",
      "state": "PROCESSING"
    }
  },
  "jsonrpc": "2.0"
}
```

If there are no error messages, BEMS sends the following notification to the BlackBerry Connect app and disables the group discussion.

```
{
  "id": "c5",
```

```

"sequence":1018694300000010,
"result":
{
  "data":
  {
    "method":"pc.DisableRoom",
    "state":"COMPLETE"
  }
},
"jsonrpc":"2.0"
}

```

## METHOD\_PC\_GetCategories

This method lists the categories that the group discussion is placed under. Group discussions can be placed only under one category. If a category is not specified, the instant messaging server randomly selects a category.

### Notification

The following table describes the notifications that BEMS might send to the BlackBerry Connect app after it processes the request.

| parameter  | Type           | Description   |           |      |             |      |        |  |    |        |   |
|------------|----------------|---|-----------|------|-------------|------|--------|--|----|--------|---|
| categories | Category Array | This parameter specifies a list of categories. Each category includes the following information: <table border="1" data-bbox="649 1071 1445 1333"> <thead> <tr> <th>Parameter</th> <th>Type</th> <th>Description</th> </tr> </thead> <tbody> <tr> <td>name</td> <td>String</td> <td>This parameter specifies the category name for the discussion group.</td> </tr> <tr> <td>id</td> <td>String</td> <td>This parameter specifies the category ID of the discussion group.</td> </tr> </tbody> </table> | Parameter | Type | Description | name | String | This parameter specifies the category name for the discussion group. | id | String | This parameter specifies the category ID of the discussion group. |
| Parameter  | Type           | Description   |           |      |             |      |        |  |    |        |   |
| name       | String         | This parameter specifies the category name for the discussion group.  |           |      |             |      |        |  |    |        |   |
| id         | String         | This parameter specifies the category ID of the discussion group.   |           |      |             |      |        |  |    |        |   |

### Code example

The following example sends a request to BEMS to retrieve the categories for the group discussion.

```

{
  "method":"pc.GetCategories",
  "params": {},
  "id":"c5",
  "jsonrpc":"2.0"
}

```

If the request is successful, BEMS sends the following response to the BlackBerry Connect app and processes the request.

```

{
  "id":"c5",

```

```

"error":null,
"result":
{
  "data":
  {
    "method":"pc.GetCategories",
    "state":"PROCESSING"
  }
},
"jsonrpc":"2.0",
"background":false
}

```

If no error messages are returned, BEMS sends the following notification, including the group discussion names and category to the BlackBerry Connect app and displays the information.

```

{
  "id":"c5",
  "sequence":1018682300000006,
  "result":
  {
    "data":
    {
      "method":"pc.GetCategories",
      "Categories":
      [
        {
          "name":"ITRestricted",
          "id":"ma-cat://gems.sw.rim.net/25ac15e7-9bff-4e78-9261-6e08aa43231e"
        },
        {
          "name":"Public Use",
          "id":"ma-cat://gems.sw.rim.net/0772c8f8-0763-47a8-a98d-478cfb389443"
        }
      ],
      "method":"pc.GetCategories",
      "state":"COMPLETE"
    }
  },
  "jsonrpc":"2.0"
}

```

## METHOD\_PC\_GetRoom

This method retrieves the group discussion details.

| Parameter | Type   | Required | Description  |
|-----------|--------|----------|--|
| roomId    | String | √        | This parameter specifies the ID of the group discussion. |

### Notification

The following table describes the notifications that BEMS might send to the BlackBerry Connect app after it processes the request.

| Parameter       | Type            | Description  |           |      |             |      |        |   |    |        |   |      |        |  |             |        |   |
|-----------------|-----------------|--|-----------|------|-------------|------|--------|---|----|--------|---|------|--------|--|-------------|--------|---|
| id              | String          | This parameter specifies the group discussion ID.  |           |      |             |      |        |   |    |        |   |      |        |  |             |        |   |
| name            | String          | This parameter specifies the group discussion name.  |           |      |             |      |        |   |    |        |   |      |        |  |             |        |   |
| description     | String          | This parameter specifies the description of the group discussion.  |           |      |             |      |        |   |    |        |   |      |        |  |             |        |   |
| category        | String          | This parameter specifies the category ID of the group discussion it is placed under.   |           |      |             |      |        |   |    |        |   |      |        |  |             |        |   |
| privacy         | String          | This parameter specifies the security level of the group discussion.   |           |      |             |      |        |   |    |        |   |      |        |  |             |        |   |
| isMemberOf      | Boolean         | This parameter specifies if the user is a member of the group discussion.  |           |      |             |      |        |   |    |        |   |      |        |  |             |        |   |
| isManagerOf     | Boolean         | This parameter specifies if the user is a manager of the group discussion.   |           |      |             |      |        |   |    |        |   |      |        |  |             |        |   |
| isDisabled      | Boolean         | This parameter specifies if the group discussion is disabled.  |           |      |             |      |        |   |    |        |   |      |        |  |             |        |   |
| skipInvitations | Boolean         | <p>This parameter specifies if an invitation should not be sent. By default, this parameter is set to False.</p> <ul style="list-style-type: none"> <li>• If true, an invitation is sent.</li> <li>• If false, the invitation is not sent, but inherited from the category parameter.</li> </ul>   |           |      |             |      |        |   |    |        |   |      |        |  |             |        |   |
| managers        | Principal Array | This parameter specifies an Array of Principals. Each array includes the following parameters:   |           |      |             |      |        |   |    |        |   |      |        |  |             |        |   |
| members         | Principal Array |  |           |      |             |      |        |   |    |        |   |      |        |  |             |        |   |
|                 |                 | <table border="1"> <thead> <tr> <th>Parameter</th> <th>Type</th> <th>Description</th> </tr> </thead> <tbody> <tr> <td>name</td> <td>String</td> <td>This parameter specifies the name of the user or group.</td> </tr> <tr> <td>id</td> <td>String</td> <td>This parameter specifies the ID of the user or group.</td> </tr> <tr> <td>type</td> <td>String</td> <td> <p>This parameter specifies the manager or member as one of the following:</p> <ul style="list-style-type: none"> <li>• user</li> <li>• group</li> </ul> </td> </tr> <tr> <td>displayName</td> <td>String</td> <td>This parameter specifies the display name of the user or group.</td> </tr> </tbody> </table> | Parameter | Type | Description | name | String | This parameter specifies the name of the user or group. | id | String | This parameter specifies the ID of the user or group. | type | String | <p>This parameter specifies the manager or member as one of the following:</p> <ul style="list-style-type: none"> <li>• user</li> <li>• group</li> </ul> | displayName | String | This parameter specifies the display name of the user or group. |
| Parameter       | Type            | Description  |           |      |             |      |        |   |    |        |   |      |        |  |             |        |   |
| name            | String          | This parameter specifies the name of the user or group.  |           |      |             |      |        |   |    |        |   |      |        |  |             |        |   |
| id              | String          | This parameter specifies the ID of the user or group.  |           |      |             |      |        |   |    |        |   |      |        |  |             |        |   |
| type            | String          | <p>This parameter specifies the manager or member as one of the following:</p> <ul style="list-style-type: none"> <li>• user</li> <li>• group</li> </ul>   |           |      |             |      |        |   |    |        |   |      |        |  |             |        |   |
| displayName     | String          | This parameter specifies the display name of the user or group.  |           |      |             |      |        |   |    |        |   |      |        |  |             |        |   |

## Code example

The following example sends a request to BEMS to retrieve the group discussion details.

```
{
  "method": "pc.GetRoom",
  "params":
  {
    "roomId": "ma-chan://gems.sw.rim.net/25ac15e7-9bff-4e78-9261-6e08aa43231e"
  },
  "id": "c5",
  "jsonrpc": "2.0"
}
```

If the request is successful, BEMS sends the following response to the BlackBerry Connect app and processes the request.

```
{
  "id": "c5",
  "error": null,
  "result":
  {
    "data":
    {
      "method": "pc.GetRoom",
      "state": "PROCESSING"
    }
  },
  "jsonrpc": "2.0",
  "background": false
}
```

If no error messages are returned, BEMS sends the following notification to the BlackBerry Connect app and displays the group discussion details.

```
{
  "id": "c5",
  "sequence": 1018695900000011,
  "result":
  {
    "data":
    {
      "id": "ma-chan://gems.sw.rim.net/25ac15e7-9bff-4e78-9261-6e08aa43231e",
      "name": "Surprise retirement celebration",
      "category": "ma-cat://gems.sw.rim.net/9d58ae36-7490-47d4-8a55-56b2d21ae6e3",
      "description": "Discuss potluck options",
      "privacy": "Secret",
      "isMemberOf": true,
      "isManagerOf": true,
      "skipInvitations": false,
      "isDisabled": false,
      "managers":
      [
        {
          "id": "sip:user1@example.com",
          "name": "User1",
          "type": "user",
          "displayName": "User 1"
        }
      ]
    }
  },
}
```

```

    {
      "id": "ma-grp://gem.sw.rim.net/52cb55f8-5fee-3a78-9271-7d18bb6323cc",
      "name": "DesertMenuGroup",
      "type": "group",
      "displayName": "Desert Menu Group"
    }
  ],
  "members":
  [
    {
      "id": "sip:user1@example.com",
      "name": "User1",
      "type": "user",
      "displayName": "User 1"
    },
    {
      "id": "sip:user2@example.com",
      "name": "User2",
      "type": "user",
      "displayName": "User 2"
    }
  ]
  "skipInvitations": false,
  "isDisabled": true,
  "method": "pc.GetRoom",
  "state": "COMPLETE"
}
},
"jsonrpc": "2.0"
}

```

## METHOD\_PC\_UpdateRoom

This method sends a request to BEMS to update the group discussion settings.

**Note:** At least one parameter must be included in this method. If a parameter is not included, then the value is not updated for the group discussion.

The following table describes the parameters that you can include in the METHOD\_PC\_UpdateRoom method.

| Parameter      | Type   | Required | Description   |
|----------------|--------|----------|---|
| roomId         | String | √        | This parameter specifies the ID of the group discussion to update.  |
| newName        | String | —        | This parameter specifies the new name for the group discussion. The updated name can be a maximum of 256 alphanumeric, numeric, special characters or a combination of these. This includes spaces. |
| newDescription | String | —        | This parameter specifies the updated description of the group discussion. The updated name can be a maximum of 256 characters. This includes spaces.  |



| Parameter          | Type    | Required | Description  |
|--------------------|---------|----------|--|
| newPrivacy         | String  | –        | This parameter specifies the updated security level of the group discussion.   |
| newCategory        | String  | –        | This parameter specifies the new category that the group discussion should move under.   |
| newSkipInvitations | Boolean | –        | This parameter specifies if an invitation is sent. By default, this parameter is set to False. <ul style="list-style-type: none"> <li>• If true, an invitation is sent.</li> <li>• If false, the invitation is not sent, but inherited from the category parameter.</li> </ul> |

### InnerError

The following lists the errors that might occur when updating a group discussion:

- Name of group discussion is used by another group discussion. Group discussion names must be unique.

### Code example

The following example sends a request to BEMS to rename the Surprise retirement celebration discussion group to Surprise retirement.

```
{
  "method": "pc.UpdateRoom",
  "params":
  {
    "roomId": "ma-chan://gems.sw.rim.net/25ac15e7-9bff-4e78-9261-6e08aa43231e",
    "newName": "Surprise retirement"
  },
  "id": "c5",
  "jsonrpc": "2.0"
}
```

If the request is successful, BEMS sends the following response to the BlackBerry Connect app and processes the request.

```
{
  "id": "c5",
  "error": null,
  "result":
  {
    "data":
    {
      "method": "pc.UpdateRoom",
      "state": "PROCESSING"
    }
  },
  "jsonrpc": "2.0",
  "state": "PROCESSING"
}
```

If no error messages are returned, BEMS sends the following notification to the BlackBerry Connect app and renames the group discussion.

```
{
  "id": "c5",
  "sequence": 1018697900000013,
  "result": {
    "data": {
      "method": "pc.UpdateRoom",
      "state": "COMPLETE"
    }
  }
  "jsonrpc": "2.0"
}
```

## METHOD\_PC\_UpdateRoomUsers

This method updates the members and managers in a group discussion.

The following table describes the parameters that you can include in this method.

| Parameter       | Type         | Required | Description  |
|-----------------|--------------|----------|--|
| roomId          | String       | ✓        | This parameter specifies the ID of the group discussion to update members and managers for.  |
| membersToAdd    | String Array | –        | This parameter specifies a list of users or user groups to add to the group discussion. The category must allow users specified to be a member. Individual users and Active Directory user groups can be added as members.   |
| membersToRemove | String Array | –        | This parameter specifies a list of members to remove from the group discussion. Individual users and Active Directory user groups can be removed from the members list.  |
| members         | String Array | –        | This parameter specifies a list of users to join the group discussion and participate as a member. This list replaces the existing members list. The room category must allow the user specified to be a member. Individual users and Active Directory user groups can be set as group discussion members. |
| managersToAdd   | String Array | –        | This parameter specifies a list of users or user groups to add as managers. The room category must allow the user or user group specified to be a manager. Individual users and Active Directory user groups can be added as managers.   |

| Parameter        | Type         | Required | Description  |
|------------------|--------------|----------|--|
| managersToRemove | String Array | –        | This parameter specifies a list of members to remove from the group discussion. Individual users and Active Directory user groups can be removed from the manager list.  |
| managers         | String Array | –        | This parameter specifies users that can manage a group discussion. Managers are automatically added as members. This list replaces the existing managers list. Individual users and Active Directory user groups can be set as managers of a group discussion.<br><br><b>Note:</b> Each group discussion must have one or more managers. |

### Notification

The following table describes the notification that BEMS might send to the BlackBerry Connect app after it processes the request.

| Parameter  | Type       | Description  |
|------------|------------|--|
| innerError | Json Array | This parameter specifies an array of errors that might occur when updating group discussion members and managers. See InnerError below for more information. |

### InnerError

The following errors might occur when updating the group discussion members and managers:

- The manager or member is not a valid instant messaging user or Active Directory user group.
- The manager or member specified is not allowed to be a manager or member in the group discussion as per the category specification.
- A group discussion with the specified ID does not exist.

The following table describes the parameters that are included for innererrors.

| Parameter   | Type         | Description   |
|-------------|--------------|---|
| type        | String       | This parameter specifies the error type.  |
| parameter   | String       | This parameter specifies parameter name if the error is caused by an input parameter. This is Optional. |
| errorValues | String Array | This parameter specifies a list of invalid values. This is optional.                                    |
| message     | String       | This parameter specifies an error message.  |

### Tip:

- An empty members list removes all members from the group discussion.

- If membersToAdd, managersToAdd, membersToRemove, and managersToRemove are provided, at least one of the parameters must contain a value.
- The members and managers parameters replace all members and managers in the list respectively. MembersToAdd, membersToRemove provide members to add or remove from the list. As a result, both membersToAdd and membersToRemove parameters and members cannot be in the same request.

### Code example

The following example sends a request to BEMS to add and remove contacts in a group discussion.

```
{
  "method": "pc.UpdateRoomUsers",
  "params": {
    "roomId": "ma-chan://gems.sw.rim.net/25ac15e7-9bff-4e78-9261-6e08aa43231e",
    "managersToAdd": [ "sip:user1@example.com", "sip:user2@example.com" ],
    "membersToRemove": [ "sip:user3@example.com", "sip:user4@example.com",
      "sip:user5@example.com" ]
  },
  "id": "c5",
  "jsonrpc": "2.0"
}
```

If the request is successful, BEMS sends the following response to the BlackBerry Connect app and processes the request.

```
{
  "id": "c5",
  "error": null,
  "result": {
    "data": {
      "method": "pc.UpdateRoomUsers",
      "state": "PROCESSING"
    }
  },
  "jsonrpc": "2.0"
}
```

If there are errors, BEMS sends the following notification to the BlackBerry Connect app and the error message (for example, a user is not found).

```
{
  "id": "c5",
  "sequence": 1018698900000014,
  "result": {
    "data": {
      "innerError": [
        {
          "method": "pc.UpdateRoomUsers",
          "innerError": [
            {
              "type": "parameterError",
              "parameter": "members",
              "errorValues": [ "sip:user1@example.com", "sip:user2@example.com" ],
              "message": "User not found"
            }
          ]
        }
      ]
    }
  }
}
```

```
    }  
  ],  
  "method": "pc.UpdateRoomUsers",  
  "state": "COMPLETE"  
},  
"jsonrpc": "2.0"  
}
```

# User methods

This section provides information about APIs that complete user persistent chat tasks. The following user methods are available:

- [METHOD\\_PC\\_FollowRooms](#)
- [METHOD\\_PC\\_GetChatHistory](#)
- [METHOD\\_PC\\_GetMyRooms](#)
- [METHOD\\_PC\\_GetRoomParticipants](#)
- [METHOD\\_PC\\_JoinRoom](#)
- [METHOD\\_PC\\_LeaveRoom](#)
- [METHOD\\_PC\\_MuteRooms](#)
- [METHOD\\_PC\\_SearchRooms](#)
- [METHOD\\_PC\\_SendMessage](#)
- [METHOD\\_PC\\_FileUpload](#)
- [METHOD\\_PC\\_FileDownload](#)

## METHOD\_PC\_FollowRooms

This method sends a request to BEMS to follow or unfollow a discussion room. When users follow a group discussion, they automatically join the group discussion and can participate in and receive events associated with the group discussion.

**Note:** Followed group discussion rooms are persistent on the instant messaging server, and the followed group discussion rooms list is per user and not per device. This allows lists to be shared across devices and the desktop client.

The following table describes the parameters that you can include in this method.

| Parameter       | Type         | Required | Description  |
|-----------------|--------------|----------|--|
| roomsToFollow   | String Array | —*       | This parameter specifies a list of group discussion IDs that users can follow and participate in.  |
| roomsToUnfollow | String Array | —*       | This parameter specifies a list of group discussion IDs that users can unfollow. When users unfollow a group discussion they stop receiving notifications from the group discussion.   |
| replaceList     | Boolean      | ✓        | This parameter specifies one of the following actions: <ul style="list-style-type: none"><li>• If true, the list of group discussions on the instant messaging server is replaced with the new list.</li><li>• If false, the instant messaging server adds or removes rooms from the list of group discussions that users are following.</li></ul> |

\* If replaceList is true, then the roomsToFollow is required and roomsToUnfollow should not be passed in. If replaceList is false, either the roomsToFollow or roomsToUnfollow parameter must be passed in.

## Code example

The following example sends a request to BEMS to follow and unfollow specified group discussions.

```
{
  "method": "pc.FollowRooms",
  "params":
  {
    roomsToFollow:[
      "ma-chan://gems.example.com/25ac15e7-9bff-4e78-9261-6e08aa43231e",
      "ma-chan://gems.example.com/d19de8b1-469c-4a92-a8c0-f5e37ba62db6"
    ],
    roomsToUnfollow:[
      "ma-chan://gems.example.com/f7972fdb-7ea9-4d7f-be4c-d27c8d9c44bc",
      "ma-chan://gems.example.com/a15593ae-3a4e-414c-b33f-deb077136362"
    ],
    replaceList: true
  },
  "id": "c5",
  "jsonrpc": "2.0"
}
```

If the request is successful, BEMS sends the following response to the BlackBerry Connect app and processes the request.

```
{
  "id": "c5",
  "error": null,
  "result":
  {
    "data":
    {
      "method": "pc.FollowRooms",
      "state": "PROCESSING"
    }
  },
  "jsonrpc": "2.0"
}
```

If there are no error messages, BEMS sends the following notification to the BlackBerry Connect app and the user follows and unfollows the specified group discussions.

```
{
  "id": "c5",
  "sequence": 1018829700000047,
  "result":
  {
    "data":
    {
      "method": "pc.FollowRooms",
      "state": "COMPLETE"
    }
  },
  "jsonrpc": "2.0"
}
```

## METHOD\_PC\_GetChatHistory

This method sends a request to BEMS to return the chat history for a group discussion.

| Parameter      | Type         | Required | Description   |
|----------------|--------------|----------|---|
| roomsId        | String       | ✓        | This parameter specifies a list of group discussion IDs that a user can view the chat history for.  |
| resultLimit    | Number       | —        | This parameter specifies the maximum number of messages that a user can see in the group discussion. By default, the maximum number of group discussion messages a user can see is 20. Users can view messages in batches of 20 messages or less. |
| searchString   | String       | —        | This parameter specifies the string to search for in the group discussion chat history.   |
| authors        | String Array | —        | This parameter specifies a list of users that sent messages in the group discussion that users can search for.  |
| startDate      | Number       | —        | This parameter specifies the start date of the group discussion chat history. The startDate is specified in epoch time format.  |
| endDate        | Number       | —        | This parameter specifies the end date of the group discussion chat history. The endDate is specified in epoch time format.  |
| afterMessageId | String       | —        | This parameter specifies the message ID after which to retrieve messages sent to the group discussion. If this parameter is specified, the startDate is disregarded.  |
| chronological  | Boolean      | —        | This parameter lists the group discussion messages in chronological order. By default, the order is false and the messages appear in reverse chronological order.   |

### Notification

The following table describes the parameters that BEMS returns and the notifications that are sent to the BlackBerry Connect app when users request the chat history.



| Parameter         | Type          | Description  |           |      |             |         |        |   |           |        |  |          |        |   |                   |        |  |         |         |   |           |        |  |               |        |   |
|-------------------|---------------|--|-----------|------|-------------|---------|--------|---|-----------|--------|--|----------|--------|---|-------------------|--------|--|---------|---------|---|-----------|--------|--|---------------|--------|---|
| messages          | Message Array | This parameter lists the messages in the group discussion. Each message includes the following information: <table border="1" data-bbox="513 350 1446 1213"> <thead> <tr> <th>Parameter</th> <th>Type</th> <th>Description</th> </tr> </thead> <tbody> <tr> <td>message</td> <td>String</td> <td>This parameter specifies the message content.</td> </tr> <tr> <td>messageId</td> <td>String</td> <td>This parameter specifies the message ID of the message sent.</td> </tr> <tr> <td>authorId</td> <td>String</td> <td>This parameter specifies the ID of the contact that sent the message.</td> </tr> <tr> <td>authorDisplayName</td> <td>String</td> <td>This parameter displays the sender's name.</td> </tr> <tr> <td>isAlert</td> <td>Boolean</td> <td>This parameter specifies that the message is flagged as an alert message. By default, this parameter is set to False.</td> </tr> <tr> <td>timeStamp</td> <td>Number</td> <td>This parameter specifies the time stamp date of the message sent to the group discussion. The timeStamp is specified in epoch time format.</td> </tr> <tr> <td>fileLinkCount</td> <td>Number</td> <td>This parameter specifies the number of file links in the message.</td> </tr> </tbody> </table> | Parameter | Type | Description | message | String | This parameter specifies the message content. | messageId | String | This parameter specifies the message ID of the message sent. | authorId | String | This parameter specifies the ID of the contact that sent the message. | authorDisplayName | String | This parameter displays the sender's name. | isAlert | Boolean | This parameter specifies that the message is flagged as an alert message. By default, this parameter is set to False. | timeStamp | Number | This parameter specifies the time stamp date of the message sent to the group discussion. The timeStamp is specified in epoch time format. | fileLinkCount | Number | This parameter specifies the number of file links in the message. |
| Parameter         | Type          | Description  |           |      |             |         |        |   |           |        |  |          |        |   |                   |        |  |         |         |   |           |        |  |               |        |   |
| message           | String        | This parameter specifies the message content.  |           |      |             |         |        |   |           |        |  |          |        |   |                   |        |  |         |         |   |           |        |  |               |        |   |
| messageId         | String        | This parameter specifies the message ID of the message sent.   |           |      |             |         |        |   |           |        |  |          |        |   |                   |        |  |         |         |   |           |        |  |               |        |   |
| authorId          | String        | This parameter specifies the ID of the contact that sent the message.  |           |      |             |         |        |   |           |        |  |          |        |   |                   |        |  |         |         |   |           |        |  |               |        |   |
| authorDisplayName | String        | This parameter displays the sender's name.   |           |      |             |         |        |   |           |        |  |          |        |   |                   |        |  |         |         |   |           |        |  |               |        |   |
| isAlert           | Boolean       | This parameter specifies that the message is flagged as an alert message. By default, this parameter is set to False.  |           |      |             |         |        |   |           |        |  |          |        |   |                   |        |  |         |         |   |           |        |  |               |        |   |
| timeStamp         | Number        | This parameter specifies the time stamp date of the message sent to the group discussion. The timeStamp is specified in epoch time format.   |           |      |             |         |        |   |           |        |  |          |        |   |                   |        |  |         |         |   |           |        |  |               |        |   |
| fileLinkCount     | Number        | This parameter specifies the number of file links in the message.  |           |      |             |         |        |   |           |        |  |          |        |   |                   |        |  |         |         |   |           |        |  |               |        |   |
| moreResults       | Boolean       | This parameter specifies whether more results are available. <ul style="list-style-type: none"> <li>• If true, more results are available, but were not returned because of the set resultLimit parameter.</li> <li>• If false, then all the results are returned.</li> </ul>  |           |      |             |         |        |   |           |        |  |          |        |   |                   |        |  |         |         |   |           |        |  |               |        |   |

### Code example

The following example sends a request to BEMS to return the chat history of a group discussion room. In this example, the request retrieves messages in batches of 20 messages as specified by the resultLimit.

```
{
  "method": "pc.GetChatHistory",
  "params":
  {
    "roomId": "ma-chan://gems.example.com/25ac15e7-9bff-4e78-9261-6e08aa43231e",
    "resultLimit": 20
  },
  "id": "c5",
  "jsonrpc": "2.0"
}
```

```
}
```

If the request is successful, BEMS sends the following response to the BlackBerry Connect app and processes the request.

```
{
  "id": "c5",
  "error": null,
  "result": {
    "data": {
      "method": "pc.GetChatHistory",
      "state": "PROCESSING"
    }
  },
  "jsonrpc": "2.0"
}
```

If there are no errors, BEMS displays the message history and includes information about the user that posted the messages to the discussion group, when the message was sent, any links the message might include, and if more results are available.

```
{
  "id": "c5",
  "sequence": 1018819000000039,
  "result": {
    "data": {
      "method": "pc.GetChatHistory",
      "messages": [
        {
          "message": "Release build ready",
          "messageId": "125988FKKFJFHI2345",
          "authorId": "sip:user1@example.com",
          "authorDisplayName": "User 1",
          "isAlert": false,
          "fileLinkCount": 0,
          "timeStamp": 1487015504
        },
        {
          "message": "Is the release build done?",
          "messageId": "125988FKKFJFHI21344",
          "authorId": "sip:user2@example.com",
          "authorDisplayName": "User 2",
          "isAlert": false,
          "fileLinkCount": 0,
          "timeStamp": 14870132441
        }
      ],
      "moreResults": false,
      "method": "pc.GetChatHistory",
      "state": "COMPLETE"
    }
  },
  "jsonrpc": "2.0"
}
```

## METHOD\_PC\_GetMyRooms

This method sends a request to BEMS to return a list of group discussions that the user is a manager of, a member of, following, has joined, or been invited to.

The following table describes the parameters that you can include in this method.

**Note:** One or more parameters must be true for the method to be successful. If multiple parameters are true, only the rooms that meet all of the parameters are retrieved and listed for the current user.

| Parameter   | Type    | Required | Description  |
|-------------|---------|----------|--|
| isMemberOf  | Boolean | —        | This parameter specifies a list of group discussions that the user is a member of. By default, this value is false.          |
| isManagerOf | Boolean | —        | This parameter specifies a list of group discussions that the user is a manager of. By default, the value is false.          |
| isFollowing | Boolean | —        | This parameter specifies a list of group discussions that the user is following. By default, this value is false.            |
| hasJoined   | Boolean | —        | This parameter specifies a list of group discussions that the user has joined and not left. By default, this value is false. |
| isInvitedTo | Boolean | —        | This parameter specifies a list of group discussions that the user is invited to. By default, this value is false.           |

### Notification

The following table describes the parameters that BEMS returns and the notifications to send to the BlackBerry Connect app when users request a list of the group discussions that they are a manager of, a member of, following, joined, or invited to.

| Parameter            | Type       | Description   |           |      |             |    |        |  |      |        |  |             |        |   |                      |        |  |          |         |   |
|----------------------|------------|---|-----------|------|-------------|----|--------|--|------|--------|--|-------------|--------|---|----------------------|--------|--|----------|---------|---|
| rooms                | Room Array | This parameter specifies the following information for each group discussion: <table border="1" data-bbox="672 352 1446 1184"> <thead> <tr> <th>Parameter</th> <th>Type</th> <th>Description</th> </tr> </thead> <tbody> <tr> <td>id</td> <td>String</td> <td>This parameter specifies the ID of the group discussion.</td> </tr> <tr> <td>name</td> <td>String</td> <td>This parameter specifies the name of the group discussion.</td> </tr> <tr> <td>description</td> <td>String</td> <td>This parameter specifies a description of the group discussion.</td> </tr> <tr> <td>numberOfParticipants</td> <td>Number</td> <td>This parameter specifies the number of participants that have joined the group discussion.</td> </tr> <tr> <td>isJoined</td> <td>Boolean</td> <td>This parameter specifies if the user has joined the group discussion.</td> </tr> </tbody> </table> | Parameter | Type | Description | id | String | This parameter specifies the ID of the group discussion. | name | String | This parameter specifies the name of the group discussion. | description | String | This parameter specifies a description of the group discussion. | numberOfParticipants | Number | This parameter specifies the number of participants that have joined the group discussion. | isJoined | Boolean | This parameter specifies if the user has joined the group discussion. |
| Parameter            | Type       | Description   |           |      |             |    |        |  |      |        |  |             |        |   |                      |        |  |          |         |   |
| id                   | String     | This parameter specifies the ID of the group discussion.  |           |      |             |    |        |  |      |        |  |             |        |   |                      |        |  |          |         |   |
| name                 | String     | This parameter specifies the name of the group discussion.  |           |      |             |    |        |  |      |        |  |             |        |   |                      |        |  |          |         |   |
| description          | String     | This parameter specifies a description of the group discussion.   |           |      |             |    |        |  |      |        |  |             |        |   |                      |        |  |          |         |   |
| numberOfParticipants | Number     | This parameter specifies the number of participants that have joined the group discussion.  |           |      |             |    |        |  |      |        |  |             |        |   |                      |        |  |          |         |   |
| isJoined             | Boolean    | This parameter specifies if the user has joined the group discussion.   |           |      |             |    |        |  |      |        |  |             |        |   |                      |        |  |          |         |   |
| lastInvitationId     | Number     | This parameter specifies the ID of the group discussion for which the user received an invitation to join.  |           |      |             |    |        |  |      |        |  |             |        |   |                      |        |  |          |         |   |

### Code example

The following code example sends a request to BEMS to return a list of group discussions that the user has joined and is a member of.

```
{
  "method": "pc.GetMyRooms",
  "params":
  {
    "isMemberOf": true,
    "hasJoined": true
  },
  "id": "c5",
  "jsonrpc": "2.0"
}
```

If the request is successful, BEMS sends the following response to the BlackBerry Connect app and processes the request.

```
{
  "id": "c5",
  "error": null,
  "result": {
    {
      "data": {
        {
          "method": "pc.GetMyRooms",
          "state": "PROCESSING"
        }
      },
      "jsonrpc": "2.0"
    }
  }
}
```

If no error messages are returned, BEMS sends the following notification and returns the list of group discussions. In this example, the user is a member of the Retirement Discussion group discussion and includes 15 participants.

```
{
  "id": "c5",
  "sequence": 1018820500000040,
  "result": {
    {
      "data": {
        {
          "rooms": [
            {
              "id": "ma-chan://gems.sw.rim.net/25ac15e7-9bff-4e78-9261-6e08aa43231e",
              "name": "Retirement Discussion",
              "description": "Discuss food options",
              "numberOfParticipants": 15,
              "isJoined": true
            }
          ],
          "method": "pc.GetMyRooms",
          "state": "COMPLETE"
        }
      },
      "jsonrpc": "2.0"
    }
  }
}
```

## METHOD\_PC\_GetRoomParticipants

This method sends a request to BEMS to retrieve a list of the participants in the group discussion that the user has joined.

The following table describes the parameters that you can include in this method.

| Parameter | Type   | Required | Description   |
|-----------|--------|----------|---|
| roomId    | String | √        | This parameter specifies the ID of the group discussion rooms that you want to retrieve the participant list for. |

The following table describes the parameters that BEMS returns and the notifications to send to the BlackBerry Connect app when users request the participant list.

| Parameter    | Type              | Description   |           |      |             |    |        |   |      |        |   |             |        |   |
|--------------|-------------------|---|-----------|------|-------------|----|--------|---|------|--------|---|-------------|--------|---|
| participants | Participant Array | This parameter specifies an array of participants items in the group discussion: <table border="1" data-bbox="540 432 1446 821"> <thead> <tr> <th>Parameter</th> <th>Type</th> <th>Description</th> </tr> </thead> <tbody> <tr> <td>id</td> <td>String</td> <td>This parameter specifies the participants' ID (for example, a SIP address).</td> </tr> <tr> <td>name</td> <td>String</td> <td>This parameter specifies the participants' names.</td> </tr> <tr> <td>displayName</td> <td>String</td> <td>This parameter specifies the participants' display names.</td> </tr> </tbody> </table> | Parameter | Type | Description | id | String | This parameter specifies the participants' ID (for example, a SIP address). | name | String | This parameter specifies the participants' names. | displayName | String | This parameter specifies the participants' display names. |
| Parameter    | Type              | Description   |           |      |             |    |        |   |      |        |   |             |        |   |
| id           | String            | This parameter specifies the participants' ID (for example, a SIP address).   |           |      |             |    |        |   |      |        |   |             |        |   |
| name         | String            | This parameter specifies the participants' names.   |           |      |             |    |        |   |      |        |   |             |        |   |
| displayName  | String            | This parameter specifies the participants' display names.   |           |      |             |    |        |   |      |        |   |             |        |   |

### Code example

The following example sends a request to BEMS to return the participants list for a group discussion.

```
{
  "method": "pc.GetRoomParticipants",
  "params":
  {
    "roomID": "ma-chan://gems.example.com/25ac15e7-9bff-4e78-9261-6e08aa43231e"
  },
  "id": "c5",
  "jsonrpc": "2.0"
}
```

If the request is successful, BEMS sends the following response to the BlackBerry Connect app and processes the request.

```
{
  "id": "c5",
  "error": null,
  "result":
  {
    "data":
    {
      "method": "pc.GetRoomParticipants",
      "state": "PROCESSING"
    }
  },
  "jsonrpc": "2.0"
}
```

If there are no errors, BEMS sends the following notification to the BlackBerry Connect app and displays the participants in the group discussion. In this example, the participant names, display names, and SIP addresses are displayed for the specified room ID.

```
{
  "id": "c5",
  "error": null,
  "result": {
    "data": {
      "method": "pc.GetRoomParticipants",
      "participants": [
        {
          "name": "user1",
          "displayName": "User 1",
          "id": "sip:user1@example.com"
        },
        {
          "name": "user2",
          "displayName": "User 2",
          "id": "sip:user2@example.com"
        }
      ]
    }
  },
  "jsonrpc": "2.0"
}
```

## METHOD\_PC\_JoinRoom

This method sends a request to BEMS for the user to join a group discussion. The user must be a member of the group discussion to participate and receive notifications or the group discussion privacy must be set to Open.

The following table describes the parameters that you can include in this method.

| Parameter | Type   | Required | Description  |
|-----------|--------|----------|--|
| roomId    | String | √        | This parameter specifies the ID of the group discussion that the user joins. |

### Code example

The following example sends a request to BEMS for the user to join a group discussion.

```
{
  "method": "pc.JoinRoom",
  "params": {
    "roomId": "ma-cha://gems.example.com/25ac15e7-9bff-4e78-9261-6e08aa43231e"
  },
  "id": "c5",
  "jsonrpc": "2.0"
}
```

```
}
```

If the request is successful, BEMS returns the following response to the BlackBerry Connect app and processes the request.

```
{
  "id": "c5",
  "error": null,
  "result": {
    "data": {
      "method": "pc.JoinRoom",
      "state": "PROCESSING"
    }
  },
  "jsonrpc": "2.0"
}
```

If there are no errors, BEMS sends the following notification to the BlackBerry Connect app and the user joins the room.

```
{
  "id": "c5",
  "error": null,
  "result": {
    "data": {
      "method": "pc.JoinRoom"
    }
  },
  "jsonrpc": "2.0"
}
```

## METHOD\_PC\_LeaveRoom

This method sends a request to BEMS for the user to leave a group discussion room that they are a member or following. The user must be a member of the group discussion or the room privacy must be open to follow.

The following table describes the parameters that you can include in this method.

| Parameter | Type   | Required | Description   |
|-----------|--------|----------|---|
| roomId    | String | ✓        | This parameter specifies the ID of the group discussion that the user wants to leave. |

### Code example

The following example sends a request to BEMS to leave a group discussion that they are a member of.

```
{
  "method": "pc.LeaveRoom",
  "params":
```



```

{
  "roomId": "ma-chan://gems.example.com/25ac15e7-9bff-4e78-9261-6e08aa43231e"
},
{id": "c5",
"jsonrpc": "2.0"
}

```

If the request is successful, BEMS sends the following response to the BlackBerry Connect app and processes the request.

```

{
  "id": "c5",
  "error": null,
  "result":
  {
    "data":
    {
      "method": "pc.LeaveRoom",
      "state": "PROCESSING"
    }
  },
  "jsonrpc": "2.0",
  "background": false
}

```

If there are no errors, BEMS sends the following notification to the BlackBerry Connect app and the user leaves the group discussion.

```

{
  "id": "c5",
  "error": null,
  "result":
  {
    "data":
    {
      "method": "pc.LeaveRoom",
      "state": "COMPLETE"
    }
  },
  "jsonrpc": "2.0"
}

```

## METHOD\_PC\_MuteRooms

This method mutes or unmutes a group discussion that the user is a member of or following. When the user mutes a group discussion, all notifications related to the group discussion are suppressed. The BEMS-Connect service maintains a list of muted group discussions per session and this method can be used to add or remove muted group discussions from the list or replace the list with a new list.

**Note:** The METHOD\_PC\_MuteRooms does not validate the groups discussion IDs. Muting a group discussion is per session and not persistent in the Connect service. Each time BlackBerry Connect establishes a new session, the list is re-sent to the BlackBerry Connect app.

| Parameter     | Type         | Required | Description  |
|---------------|--------------|----------|--|
| roomsToMute   | String Array | —*       | This parameter specifies a list of group discussion IDs that users can mute.   |
| roomsToUnmute | String Array | —*       | This parameter specifies a list of group discussion IDs that users can unmute and receive notifications for.   |
| replaceList   | Boolean      | ✓        | This parameter specifies one of the following actions: <ul style="list-style-type: none"> <li>• If true, the list of group discussions in the BEMS-Connect service is replaced with the passed in list.</li> <li>• If false, the BEMS-Connect service adds or removes group discussions from the list of group discussions the user is following.</li> </ul> |

\* If replaceList is true, then the roomsToFollow is required and roomsToUnfollow should no be passed in. If replaceList is false, either roomsToFollow or roomsToUnfollow must be passed in.

### Code example

The following example sends a request to BEMS to mute two group discussions and unmute one group discussion.

```
{
  "method": "pc.MuteRooms",
  "params": {
    roomsToMute: [
      "ma-chan://gems.example.com/25ac15e7-9bff-4e78-9261-6e08aa43231e",
      "ma-chan://gems.example.com/d19de8b1-469c-4a92-a8c0-f5e37ba62db6"
    ],
    roomsToUnmute: [
      "ma-chan://gems.example.com/f7972fdb-7ea9-4d7f-be4c-d27c8d9c44bc"
    ],
    replaceList: true
  },
  "id": "c5",
  "jsonrpc": "2.0"
}
```

If the request is successful, BEMS sends the following response to the BlackBerry Connect app and processes the request.

```
{
  "id": "c5",
  "error": null,
  "result": {
    "data": {
      "method": "pc.MuteRooms",
      "state": "PROCESSING"
    }
  },
  "jsonrpc": "2.0",
}
```

```
"background":false
}
```

If there are no errors, BEMS sends the following notification to the BlackBerry Connect app and mutes and unmutes the specified group discussions.

```
{
  "id":"c5",
  "error":null,
  "result":
  {
    "data":
    {
      "method":"pc.MuteRooms",
      "state":"COMPLETE"
    }
  },
  "jsonrpc":"2.0"
}
```

## METHOD\_PC\_SearchRooms

This method sends a request to BEMS to search for group discussions.

The following table lists the parameters that you can include in this method.

| Parameter  | Type    | Required | Description  |
|------------|---------|----------|--|
| searchTerm | String  | √        | This parameter specifies the search term that is used to search group discussionnames and optionally the group discussions descriptions.   |
| searchDesc | Boolean | —        | This parameter specifies whether to search for group discussions using the name and description. By default, this value is true. <ul style="list-style-type: none"><li>• If true, the search query searches both the group discussion name and the description.</li><li>• If it is false, the query only searches the group discussion names.</li></ul>  |
| isMemberOf | Boolean | —        | This parameter specifies the list of group discussions that the user is a member of. By default, this value is false and the search query includes group discussions that the member is and isn't a member of.   |
| disabled   | Boolean | —        | This parameter specifies whether to include disabled group discussions in a search. By default, this value is false. <ul style="list-style-type: none"><li>• If true, group discussions that are flagged as disabled are not included in the search or returned in the search results.</li><li>• If false, group discussions that are flagged as disabled are included in the search and returned in the search results.</li></ul> |

| Parameter | Type         | Required | Description   |
|-----------|--------------|----------|---|
| privacy   | String Array | –        | <p>This parameter specifies the security level of the group discussion and if the group discussions are returned in a search. By default, this value is set to all. All of the privacy settings for group discussions are searched.</p> <p><b>Note:</b> Group discussions with the privacy set to Secret are only returned in the search query if the user is a member of the group discussion.</p> |

### BEMS response and notification

The following table describes the parameters that BEMS returns and the notification to send to the BlackBerry Connect app when users search for a group discussion.

| Parameter            | Type       | Description  |           |      |             |    |        |  |      |        |  |             |        |   |                      |        |   |
|----------------------|------------|--|-----------|------|-------------|----|--------|--|------|--------|--|-------------|--------|---|----------------------|--------|---|
| Rooms                | Json Array | <p>This parameter specifies the array of group discussions that meet the search request parameters. The following information is included for each group discussion.</p> <table border="1"> <thead> <tr> <th>Parameter</th> <th>Type</th> <th>Description</th> </tr> </thead> <tbody> <tr> <td>id</td> <td>String</td> <td>This parameter specifies the ID of the group discussion.</td> </tr> <tr> <td>name</td> <td>String</td> <td>This parameter specifies the name of the group discussion.</td> </tr> <tr> <td>description</td> <td>String</td> <td>This parameter specifies the description of the group discussion.</td> </tr> <tr> <td>numberOfParticipants</td> <td>Number</td> <td>This parameter specifies the number of participants that are in the group discussion.</td> </tr> </tbody> </table> | Parameter | Type | Description | id | String | This parameter specifies the ID of the group discussion. | name | String | This parameter specifies the name of the group discussion. | description | String | This parameter specifies the description of the group discussion. | numberOfParticipants | Number | This parameter specifies the number of participants that are in the group discussion. |
| Parameter            | Type       | Description  |           |      |             |    |        |  |      |        |  |             |        |   |                      |        |   |
| id                   | String     | This parameter specifies the ID of the group discussion.   |           |      |             |    |        |  |      |        |  |             |        |   |                      |        |   |
| name                 | String     | This parameter specifies the name of the group discussion.   |           |      |             |    |        |  |      |        |  |             |        |   |                      |        |   |
| description          | String     | This parameter specifies the description of the group discussion.  |           |      |             |    |        |  |      |        |  |             |        |   |                      |        |   |
| numberOfParticipants | Number     | This parameter specifies the number of participants that are in the group discussion.  |           |      |             |    |        |  |      |        |  |             |        |   |                      |        |   |

### Code example

The following example sends a request to BEMS to search for the retirement celebration group discussion using the search term "potluck". The search searches closed and secret group discussions. Group discussions that are disabled are not included in the search.

```
{
  "method": "pc.SearchRooms",
  "params":
  {
    "searchTerm": "potluck",
    "disabled": true,
    "privacy": ["Closed", "Secret", "Open"]
  }
}
```

```

    },
    "id": "c5",
    "jsonrpc": "2.0"
}

```

If the request is successful, BEMS sends the following response to the BlackBerry Connect app and processes the request.

```

{
  "id": "c5",
  "error": null,
  "result":
  {
    "data":
    {
      "method": "pc.SearchRooms",
      "state": "PROCESSING"
    }
  },
  "jsonrpc": "2.0"
}

```

If there are no errors, BEMS sends the following notification to the BlackBerry Connect app and displays the group discussions that match the search query. In this example, one group discussion with 15 participants matches the search query.

```

{
  "id": "c5",
  "error": null,
  "result":
  {
    "data":
    {
      "method": "pc.SearchRooms",
      "rooms":
      [
        {
          "id": "ma-chan://
gems.example.com/25ac15e7-9bff-4e78-9261-6e08aa43231e",
          "name": "Retirement celebration discussion",
          "description": "Discuss potluck options",
          "numberOfParticipants": 15
        }
      ]
    }
  },
  "jsonrpc": "2.0",
  "state": "COMPLETE"
}

```

## METHOD\_PC\_SendMessage

This method sends a message to a group discussion room that the user has joined.

The following table lists the parameters that you can include in this method.

| Parameter | Type    | Required | Description   |
|-----------|---------|----------|---|
| roomId    | String  | ✓        | This parameter specifies the ID of the group discussion that the user can send a message to.                          |
| message   | String  | ✓        | This parameter specifies the message to send to the group discussion. Messages can include links and emoticons.       |
| messageId | String  | ✓        | This parameter specifies the message ID created by the BlackBerry Connect client for the message.                     |
| isAlert   | Boolean | –        | This parameter specifies that the message is flagged as an alert message. By default, this parameter is set to False. |

### Code example

The following example sends a request to BEMS to send a message to a group discussion that the user is a member of.

```
{
  "method": "pc.SendMessage", "params":
  {
    "roomId": "ma-chan://gems.example.com/25ac15e7-9bff-4e78-9261-6e08aa43231e",
    "message": "The scaling task is complete"
    "messageId": "412405-243565-23456667"
  },
  "id": "c5",
  "jsonrpc": "2.0"
}
```

If the request is successful, BEMS sends the following response to the BlackBerry Connect app and processes the request.

```
{
  "id": "c5",
  "error": null,
  "result":
  {
    "data":
    {
      "method": "pc.SendMessage",
      "state": "PROCESSING"
    }
  },
  "jsonrpc": "2.0",
  "background": false
}
```

If there are no errors, BEMS sends the following notification to the BlackBerry Connect client and sends the message and sender's information to the group discussion.

```
{
  "id": "c5",
  "sequence": 1018830800000052,
  "result":
```

```

    {
      "data":
      {
        "messageId": "412405-243565-23456667",
        "method": "pc.SendMessage",
        "state": "COMPLETE"
      }
    },
    "jsonrpc": "2.0"
  },
  {
    "id": "S20",
    "sequence": 1018830800000053,
    "result":
    {
      "data":
      {
        "message": "The scaling task is complete",
        "clientId": "412405-243565-23456667",
        "fileRequestId": null,
        "isAlert": false,
        "messageId": 2,
        "fileLinkCount": 0,
        "roomName": "Room@15May2019",
        "authorId": "sip:user1@example.com",
        "timeStamp": 1557997700650,
        "roomId": "ma-chan://
gems.example.com/25ac15e7-9bff-4e78-9261-6e08aa43231e",
        "authorDisplayName": "User 1",
        "method": "pc.MessageReceived",
        "state": "COMPLETE"
      }
    }
  },
  "jsonrpc": "2.0"
}

```

## METHOD\_PC\_FileUpload

This method uploads a file to a group discussion. Before users can upload a file to a group discussion, users must join the the group discussion. This method requires BEMS 2.8 or later.

The following features are not supported with this method:

- Resumable uploads
- Embedded file messages: Users can add text, add a file and then add more text. This is sent as a single message.
- Icons and thumbnails are not available for the uploaded files.

For code sample information on how to upload in a group discussion, visit [msdn.microsoft.com](https://msdn.microsoft.com) to read *How to: Upload and download files to and from a Persistent Chat room*.

The following table describes the parameters that you can include in this method.

| Parameter | Type   | Required | Description   |
|-----------|--------|----------|---|
| roomId    | String | √        | This parameter specifies the group discussion ID to upload the file to. |

| Parameter     | Type   | Required | Description   |
|---------------|--------|----------|---|
| fileName      | String | ✓        | This parameter specifies the name of the file to upload to the group discussion.<br><br>Group discussion messages can include one or more embedded file links and use the following format: <code>{{file:file-name:file-path:file-size}}</code> |
| fileRequestId | String | —        | This parameter specifies the ID of the file to upload. The fileRequestID parameter allows the API call to correlate the request and response notifications. All notifications related to the file upload request include this parameter.        |
| percentDone   | Number | ✓        | This parameter specifies the percent of the file that is uploaded to BEMS.  |

### Code sample

The following example sends a request to BEMS to upload a file to a group discussion.

```
REST call URL: https://SERVER:8080/GaslampService/file/pc/ROOM-ID/FILE-NAME?
fileRequestId=FILE-REQUEST-ID
Verb: PUT
HEADERS:
Cookie:sessionId=...(text sample?)
Accept:application/json
X-User-Agent:<iOS or Android>
```

If the request fails, an appropriate error code and response body is returned that includes the file request ID.

```
HTTP/1.1 200 OK
```

BEMS sends the following notification to the BlackBerry Connect app and uploads the file to the group discussion.

```
{
  "id": "c5",
  "error": null,
  "result": {
    {
      State: PROGRESS
      "data": {
        {
          "method": "pc.FileUpload",
          "fileName": "Latest instructions",
          "roomId": "ma-chan://gems.example.com/25ac15e7-9bff-4e78-9261-6e08aa43231e",
          "percentDone": "75"
        }
      }
    },
    "jsonrpc": "2.0"
  }
}
```

If file icons, thumbnails, and picture files are made available by the instant messaging server, the icon appears in a JPEG format embedded inside of a chat message and uses the format `{{picture:PICTURE-CONTENTS}}`. Where



PICTURE-CONTENTS is byte content as a hex string (for example, {{picture:FFD8FFE0...}} is a picture that starts with bytes 0xFF, 0xD8, 0xFF, 0xE0). If a picture is associated with a file (for example, a thumbnail or an icon), then the picture content follows immediately after the file link.

## METHOD\_PC\_FileDownload

This method downloads a file from a group discussion. Before users can download a file from a group discussion, users must join the the group discussion. This method requires BEMS 2.8 or later.

The following features are not supported:

- Resumable downloads

For code sample information on how to download files from a group discussion, visit [msdn.microsoft.com](https://msdn.microsoft.com) to read *How to: Upload and download files to and from a Persistent Chat room*.

The following table describes the parameters that you can include in this method.

| Parameter     | Type   | Required | Description  |
|---------------|--------|----------|--|
| roomId        | String | ✓        | This parameter specifies the group discussion ID from which to download the file.  |
| fileName      | String | ✓        | This parameter specifies the name of the file to download from the group discussion.<br><br>Group discussion messages can include one or more embedded file links and use the following format: {{file:file-name:file-path:file-size}}       |
| fileRequestId | String | –        | This parameter specifies the ID of the file to download. The fileRequestID parameter allows the API call to correlate the request and response notifications. All notifications related to the file download request include this parameter. |
| percentDone   | Number | ✓        | This parameter provides the percentage of the file that is downloaded to BEMS.   |

### Code sample

The following example sends a request to BEMS to download a file from a group discussion.

```
REST call URL:https://SERVER:8080/GaslampService/file/pc/ROOM-ID/FILE-NAME?
fileRequestId=FILE-REQUEST-ID
Verb:PUT
HEADERS:
Cookie:sessionId=...
Accept:application/json
X-User-Agent:<iOS or Android>
```

If the request is successful, BEMS returns the following response. The response body is the file contents.

```
HTTP/1.1 200 OK
```

BEMS sends the following notifications to the BlackBerry Connect app to download the file. The file download states are Processing > Progress > Complete. The download includes a percentage of the file download that has completed.

```
{
  "id": "c5",
  "error": null,
  "result": {
    {
      State: PROGRESS
      "data": {
        {
          "method": "pc.FileDownload",
          "fileName": "Latest instructions",
          "roomId": "ma-chan://gems.example.com/25ac15e7-9bff-4e78-9261-6e08aa43231e",
          "percentDone": "75"
        }
      }
    }
  },
  "jsonrpc": "2.0"
}
```

## Response codes

| Code | Description |
|------|-------------|
| 200  | Succeeded   |

For more information about response codes, see [HTTP response codes](#).

# Event notifications

This section provides information about instant messaging and persistent chat notification APIs that users receive. The following event notifications are available and are sent from BEMS to the BlackBerry Connect client.

## Persistent chat

- [Event\\_PC\\_InvitationReceived](#)
- [Event\\_PC\\_MessageReceived](#)
- [Event\\_PC\\_ParticipantChanged](#)
- [Event\\_PC\\_RefreshContent](#)
- [Event\\_PC\\_RoomSettingsChanged](#)

## Instant messaging

- [EVENT\\_FileXferInvitationReceived](#)
- [Event\\_FileXferInvitationUpdate](#)

## Event\_PC\_InvitationReceived

This notification notifies a user that they are invited to a group discussion (for example, the user is added as a member and the group discussion room category is set to send out invitations). When users receive an invitation, they must accept the invitation to follow the group discussion.

The following table lists the parameters that you can include in this method.

| Parameter            | Type   | Description  |
|----------------------|--------|--|
| roomId               | String | This parameter specifies the ID of the group discussion that the user is invited to join                     |
| roomName             | String | This parameter specifies the name of the group discussion that the user is invited to and added as a member. |
| roomDescription      | String | This parameter specifies a description of group discussion.  |
| numberOfParticipants | Number | This parameter specifies the number of participants that have joined the group discussion.                   |
| invitationId         | Number | This parameter specifies the invitation ID for the group discussion.   |

### Code example

If the notification is successful, BEMS sends the following response to the BlackBerry Connect app and includes the discussion group's ID, name, description, number of participants that have joined the discussion group, and the invitation ID. In the following example, the user receives an invitation to join the retirement group discussion

```
{
  "id": "S38",
  "error": null,
  "result":
  {
```

```

    "data":
    {
        "roomId": "ma-chan://gems.sw.rim.net/0772c8f8-0763-47a8-a98d-478cfb389443",
        "roomName": "Retirement celebration",
        "roomDescription": "User 1 Retirement Discussion",
        "numberOfParticipants": 25,
        "invitationId": 53,
        "method": "pc.InvitationReceived"
    }
},
"jsonrpc": "2.0"
}

```

## Event\_PC\_MessageReceived

This notification specifies that a message was received in the group discussion that the user has joined.

The following table lists the parameters that you can include in this method.

| Parameter         | Type    | Description   |
|-------------------|---------|---|
| roomId            | String  | This parameter specifies the group discussion ID the message was in.  |
| roomName          | String  | This parameter specifies the name of the group discussion the message was received in.  |
| message           | String  | This parameter specifies the message content.   |
| authorId          | String  | This parameter specifies the ID of the user that sent the message to the group discussion.  |
| authorDisplayName | String  | This parameter specifies the display name of the user that sent the message to the group discussion.  |
| messageId         | String  | This parameter specifies the ID of the message sent to the group discussion.  |
| isAlert           | Boolean | This parameter specifies if the message sent to the group discussion is an alert.   |
| timeStamp         | Number  | This parameter specifies the time stamp date of the message sent to the group discussion. The timeStamp is specified in epoch time format.                                      |
| fileLinkCount     | Number  | This parameter specifies the number of file links in the message.   |
| clientMessageId   | String  | This parameter specifies that this is sent by the BlackBerry Connect client in the pc.SendMessage call. This parameter is returned only when a user receives their own message. |

## Code example

If the notification is successful, BEMS sends the following response to the BlackBerry Connect app and includes the group discussion name that the message was sent, the message, the time the message was sent, and the sender's name. In the following example, Jack sent a message to the Project updates group discussion.

```
{
  "id": "S38",
  "error": null,
  "result":
  {
    "data":
    {
      "method": "pc.MessageReceived",
      "roomId": "ma-chan://gems.sw.rim.net/25ac15e7-9bff-4e78-9261-6e08aa43231e",
      "roomName": "Project updates",
      "message": "Release build ready",
      "authorId": "sip:jackL@example.com",
      "authorDisplayName": "Jack Lemon",
      "messageId": "125988FKKFJFHI2345",
      "isAlert": false,
      "timeStamp": 1487015741
    }
  },
  "jsonrpc": "2.0"
}
```

## Event\_PC\_ParticipantChanged

This notification notifies participants in a group discussion that another participant has joined or left the group discussion.

The following table lists the parameters that you can include in this method.

| Parameter       | Type    | Description  |
|-----------------|---------|--|
| roomId          | String  | This parameter specifies the ID of the group discussion that a participant has joined or left.   |
| participantName | String  | This parameter specifies the name of the participant in the group discussion.  |
| participantId   | String  | This parameter specifies the ID of the participant in the group discussion.  |
| isActive        | Boolean | This parameter specifies the new status of the participant in the group discussion. <ul style="list-style-type: none"><li>• If true, the participant is a member of the group discussion.</li><li>• If false, the participant left the group discussion.</li></ul> |

## Code example

If the notification is successful, BEMS sends the following response to the BlackBerry Connect app to specify that a user joined or has left the group discussion. In the following example, "user3" left the group discussion.

```
{
  "id": "S38",
  "error": null,
  "result":
  {
    "data":
    {
      "roomId": "ma-chan://gems.sw.rim.net/25ac15e7-9bff-4e78-9261-6e08aa43231e",
      "method": "pc.ParticipantChanged",
      "participantName": "user 3",
      "participantId": "sip:user3@example.com",
      "isActive": False
    }
  },
  "jsonrpc": "2.0"
}
```

## Event\_PC\_RefreshContent

This notification notifies users that new content is available in the group discussion that they are a member of or following.

Users receive this notification when other events such as `pc.MessageReceived` and `pc.InvitationReceived` couldn't be sent to the BlackBerry Connect app because the BlackBerry Connect app was in the background or the BlackBerry Connect service was restarted. If BlackBerry Connect app is in background, the notification is sent when the app comes to the foreground. If BlackBerry Connect service is restarted, the notification is sent when BlackBerry Connect app first connects.

**Note:** This notification is only specified if a change is made to one of the parameters (for example, the `refreshAll`).

The following table lists the parameters that you can include in this method.

| Parameter                   | Type         | Description  |           |      |             |        |        |   |                 |        |  |                 |        |   |              |        |  |
|-----------------------------|--------------|--|-----------|------|-------------|--------|--------|---|-----------------|--------|--|-----------------|--------|---|--------------|--------|--|
| roomsWithNewMessages        | Json Array   | <p>This parameter specifies a list of group discussion IDs that include new messages for each group discussion. Each new messages includes the following parameters:</p> <table border="1"> <thead> <tr> <th>Parameter</th> <th>Type</th> <th>Description</th> </tr> </thead> <tbody> <tr> <td>roomId</td> <td>String</td> <td>This parameter specifies the ID of the group discussion that includes new messages.</td> </tr> <tr> <td>newMessageCount</td> <td>Number</td> <td>This parameter specifies the number of new messages in the group discussion.</td> </tr> </tbody> </table>  | Parameter | Type | Description | roomId | String | This parameter specifies the ID of the group discussion that includes new messages. | newMessageCount | Number | This parameter specifies the number of new messages in the group discussion. |                 |        |   |              |        |  |
| Parameter                   | Type         | Description  |           |      |             |        |        |   |                 |        |  |                 |        |   |              |        |  |
| roomId                      | String       | This parameter specifies the ID of the group discussion that includes new messages.  |           |      |             |        |        |   |                 |        |  |                 |        |   |              |        |  |
| newMessageCount             | Number       | This parameter specifies the number of new messages in the group discussion.   |           |      |             |        |        |   |                 |        |  |                 |        |   |              |        |  |
| roomsInvitedTo              | String       | <p>This parameter specifies a list of invitations that the users have received for group discussions.</p> <table border="1"> <thead> <tr> <th>Parameter</th> <th>Type</th> <th>Description</th> </tr> </thead> <tbody> <tr> <td>roomId</td> <td>String</td> <td>This parameter specifies the ID of the group discussion.</td> </tr> <tr> <td>roomName</td> <td>String</td> <td>This parameter specifies the number of new messages in the group discussion.</td> </tr> <tr> <td>roomDescription</td> <td>String</td> <td>This parameter specifies a description of the group discussion.</td> </tr> <tr> <td>invitationId</td> <td>Number</td> <td>This parameter specifies the invitation ID for the group discussion the user is invited to join.</td> </tr> </tbody> </table> | Parameter | Type | Description | roomId | String | This parameter specifies the ID of the group discussion.                            | roomName        | String | This parameter specifies the number of new messages in the group discussion. | roomDescription | String | This parameter specifies a description of the group discussion. | invitationId | Number | This parameter specifies the invitation ID for the group discussion the user is invited to join. |
| Parameter                   | Type         | Description  |           |      |             |        |        |   |                 |        |  |                 |        |   |              |        |  |
| roomId                      | String       | This parameter specifies the ID of the group discussion.   |           |      |             |        |        |   |                 |        |  |                 |        |   |              |        |  |
| roomName                    | String       | This parameter specifies the number of new messages in the group discussion.   |           |      |             |        |        |   |                 |        |  |                 |        |   |              |        |  |
| roomDescription             | String       | This parameter specifies a description of the group discussion.  |           |      |             |        |        |   |                 |        |  |                 |        |   |              |        |  |
| invitationId                | Number       | This parameter specifies the invitation ID for the group discussion the user is invited to join.   |           |      |             |        |        |   |                 |        |  |                 |        |   |              |        |  |
| roomsWithParticipantChanges | String Array | This parameter specifies a list of group discussionIDs.  |           |      |             |        |        |   |                 |        |  |                 |        |   |              |        |  |

| Parameter                | Type       | Description   |           |      |             |        |        |  |             |        |  |               |        |  |                |        |   |            |         |   |          |         |   |           |         |   |
|--------------------------|------------|---|-----------|------|-------------|--------|--------|--|-------------|--------|--|---------------|--------|--|----------------|--------|---|------------|---------|---|----------|---------|---|-----------|---------|---|
| roomsWithSettingsChanges | Json Array | <p>This parameter specifies a list of group discussions.</p> <p>The following table describes the parameters that can be included in this parameter. The parameters are only included if the setting changes.</p> <table border="1"> <thead> <tr> <th>Parameter</th> <th>Type</th> <th>Description</th> </tr> </thead> <tbody> <tr> <td>roomId</td> <td>String</td> <td>This parameter specifies the ID of the group discussion.</td> </tr> <tr> <td>newRoomName</td> <td>String</td> <td>This parameter specifies the new name of the group discussion.</td> </tr> <tr> <td>newCategoryId</td> <td>String</td> <td>This parameter specifies the new category ID for the group discussion.</td> </tr> <tr> <td>newDescription</td> <td>String</td> <td>This parameter specifies the new description of the group discussion.</td> </tr> <tr> <td>isDisabled</td> <td>Boolean</td> <td>This parameter specifies if the group discussion is disabled.</td> </tr> <tr> <td>isMember</td> <td>Boolean</td> <td>This parameter specifies if the participant has been removed from the group discussion.</td> </tr> <tr> <td>isManager</td> <td>Boolean</td> <td>This parameter specifies if the manager privileges for the group discussion have changed.</td> </tr> </tbody> </table> | Parameter | Type | Description | roomId | String | This parameter specifies the ID of the group discussion. | newRoomName | String | This parameter specifies the new name of the group discussion. | newCategoryId | String | This parameter specifies the new category ID for the group discussion. | newDescription | String | This parameter specifies the new description of the group discussion. | isDisabled | Boolean | This parameter specifies if the group discussion is disabled. | isMember | Boolean | This parameter specifies if the participant has been removed from the group discussion. | isManager | Boolean | This parameter specifies if the manager privileges for the group discussion have changed. |
| Parameter                | Type       | Description   |           |      |             |        |        |  |             |        |  |               |        |  |                |        |   |            |         |   |          |         |   |           |         |   |
| roomId                   | String     | This parameter specifies the ID of the group discussion.  |           |      |             |        |        |  |             |        |  |               |        |  |                |        |   |            |         |   |          |         |   |           |         |   |
| newRoomName              | String     | This parameter specifies the new name of the group discussion.  |           |      |             |        |        |  |             |        |  |               |        |  |                |        |   |            |         |   |          |         |   |           |         |   |
| newCategoryId            | String     | This parameter specifies the new category ID for the group discussion.  |           |      |             |        |        |  |             |        |  |               |        |  |                |        |   |            |         |   |          |         |   |           |         |   |
| newDescription           | String     | This parameter specifies the new description of the group discussion.   |           |      |             |        |        |  |             |        |  |               |        |  |                |        |   |            |         |   |          |         |   |           |         |   |
| isDisabled               | Boolean    | This parameter specifies if the group discussion is disabled.   |           |      |             |        |        |  |             |        |  |               |        |  |                |        |   |            |         |   |          |         |   |           |         |   |
| isMember                 | Boolean    | This parameter specifies if the participant has been removed from the group discussion.   |           |      |             |        |        |  |             |        |  |               |        |  |                |        |   |            |         |   |          |         |   |           |         |   |
| isManager                | Boolean    | This parameter specifies if the manager privileges for the group discussion have changed.   |           |      |             |        |        |  |             |        |  |               |        |  |                |        |   |            |         |   |          |         |   |           |         |   |
| refreshAll               | Boolean    | Specifies that content might have changed, but the individual changes can't be sent. The BlackBerry Connect app should use other methods to query all of the changes. The BlackBerry Connect app re-sends the list of group discussions to mute to the Connect service when it receives this notification.  |           |      |             |        |        |  |             |        |  |               |        |  |                |        |   |            |         |   |          |         |   |           |         |   |



## Code example

If the notification is successful, BEMS sends the following response to the BlackBerry Connect app specifying that new content is available. In the following example, a user receives a notification that new messages are available in two of the group discussions they are a member of and they received an invitation to another group discussion.

```
{
  "id": "S38",
  "error": null,
  "result": {
    "data": {
      "roomsWithNewMessages": [
        {
          "roomId": "ma-chan://gems.example.net/646c79de-9bb9-4579-aae7-
ece9d81d4ac4",
          "newMessageCount": 103
        },
        {
          "roomId": "ma-chan://gems.example.net/c6b82877-a8c4-43bf-
a451-7f794d1750e9",
          "newMessageCount": 3
        }
      ],
      "roomsInvitedTo": [
        {
          "roomId": "ma-chan://gems.example.net/0772c8f8-0763-47a8-
a98d-478cfb389443",
          "roomName": "Project Discussion",
          "roomDescription": "Project Discussion",
          "invitationId": 53,
        }
      ],
      "method": "pc.RefreshContent"
    }
  },
  "jsonrpc": "2.0"
}
```

## Event\_PC\_RoomSettingsChanged

This notification specifies that the group discussion settings have changed.

**Note:** Parameters are returned only if there is a change.

The following table lists the parameters that you can include in this method.

| Parameter   | Type   | Required | Description   |
|-------------|--------|----------|---|
| roomId      | String | ✓        | This parameter specifies the ID of the group discussion that has changed. |
| newRoomName | String | ✓        | This parameter specifies the new name of the group discussion.            |

| Parameter      | Type    | Required | Description  |
|----------------|---------|----------|--|
| newCategoryId  | String  | —        | This parameter specifies the new category ID of the group discussion.  |
| newDescription | String  | —        | This parameter specifies the new description for the group discussion.   |
| isDisabled*    | Boolean | —        | This parameter specifies if the group discussion is disabled.  |
| isMember*      | Boolean | —        | This parameter specifies if the participant has been removed from the group discussion. If false, the participant has left the room and is no longer a member.<br><br>This is returned only if the member leaves the group discussion, not if the user becomes a member. |
| isManager*     | Boolean | —        | This parameter specifies if the manager privileges for the group discussion have changed.  |

\* These parameters are returned only if the user is a participant in the group discussion.

### Code example

If the notification is successful, BEMS sends the following notification to the BlackBerry Connect client and notifies participants that the room settings changed. In this example, the name of the group discussion changed.

```
{
  "id": "S38",
  "error": null,
  "result": {
    "data": {
      "roomId": "ma-chan://gems.example.net/25ac15e7-9bff-4e78-9261-6e08aa43231e",
      "method": "pc.RoomSettingsChanged",
      "newRoomName": "SR1 Project Discussion"
    }
  },
  "jsonrpc": "2.0"
}
```

## EVENT\_FileXferInvitationReceived

This notification notifies the sender that the recipient in the one-to-one chat received the file transfer invitation. The recipient can accept or decline the file transfer.

The following table lists the parameters that you can include in this method.

| Parameter | Type   | Description   |
|-----------|--------|---|
| contactId | String | This parameter specifies the ID of the contact that sends the file. |

| Parameter | Type   | Description  |
|-----------|--------|--|
| fileName  | String | This parameter specifies the name of the file to send.   |
| fileSize  | Long   | This parameter specifies the size of the file to send.   |
| fileId    | String | This parameter specifies the file ID created by the BlackBerry Connect client for the file. This value is passed to the AcceptFileXfer method. For more information, see <a href="#">METHOD_AcceptFileXfer</a> . |
| method    | String | This parameter returns the invoked method (for example, FileXferInvitationReceived).   |

### Code example

If the notification is successful, BEMS sends the following notification to the BlackBerry Connect app and includes the file name and size. In the following example, the recipient receives an invitation from "user1" to accept a file called "MyFile".

```
{
  "id": "S38",
  "error": null,
  "result": {
    "data": {
      "contactId": "sip:user1@example.com",
      "fileName": "MyFile.txt",
      "fileSize": 55550000,
      "fileId": "dbc2e7b6-25e8-450e-9670-c9e4f32341bb",
      "method": "FileXferInvitationReceived"
    }
  },
  "jsonrpc": "2.0"
}
```

## Event\_FileXferInvitationUpdate

This notification notifies the sender that the recipient has been accepted or declined the file transfer, or that the invitation has expired. Based on the status of the event, one of the following actions occur:

- If the file transfer is accepted, file transfer initiates.
- If the file transfer is declined, no action is completed.
- If the file transfer invitation expires, the sender can send another invitation.

| Parameter | Type   | Description  |
|-----------|--------|--|
| status    | String | This parameter specifies a status of 'Accepted', 'Declined', or 'Expired'. |

| Parameter | Type   | Description  |
|-----------|--------|--|
| fileId    | String | This parameter specifies the file ID created by the BlackBerry Connect client for the file. This value is passed to the AcceptFileXfer method. For more information, see <a href="#">METHOD_AcceptFileXfer</a> . |
| method    | String | This parameter returns the invoked method (for example, FileXferInvitationUpdate).   |

### Code example

If the notification is successful, BEMS sends the following notification to the BlackBerry Connect app and includes the invitation status for the file. In the following example, the recipient accepted the file and the file is sent using the MSNFTP protocol.

```
{
  "id": "S38",
  "error": null,
  "result": {
    "data": {
      "fileId": "dbc2e7b6-25e8-450e-9670-c9e4f32341bb",
      "status": "Accepted",
      "method": "FileXferInvitationUpdate",
      "state": "COMPLETE"
    }
  },
  "jsonrpc": "2.0"
}
```

# HTTP response codes

## JSONRPC errors

| Code   | Text Code        | Description  |
|--------|------------------|--|
| -32700 | PARSE_ERROR      | An error occurred on the BEMS-Connect service while parsing the JSON text. |
| -32600 | INVALID_REQUEST  | The received JSON is not a valid JSON-RPC message.                         |
| -32601 | METHOD_NOT_FOUND | The requested remote procedure doesn't exist or is not available.          |
| -32602 | INVALID_PARAMS   | The method parameters are invalid.   |

## BEMS-Connect errors (Generic)

| Code | Text Code              | Description   |
|------|------------------------|---|
| 1004 | PARSE_ERROR            | The BEMS-Connect service can't create the chat session.                 |
| 1005 | GENERAL_FAILURE        | The BEMS-Connect service encountered a fatal error serving the request. |
| 1006 | GPS_NOT_RESPONDING     | The BlackBerry Proxy is not responding.                                 |
| 1007 | INVALID_GD_TOKEN       | The BEMS-Connect service can't verify the GD token.                     |
| 1008 | INVALID_GD_AUTHTOKEN   | The BEMS-Connect service could not verify the GD authtoken.             |
| 1009 | GPS_HTTP_ERROR         | An error response is received from the BlackBerry Proxy.                |
| 1011 | NULL_ARGUMENT          | One or more parameters are of a null value or empty.                    |
| 1012 | INVALID_ARGUMENT       | One or more arguments are not valid.                                    |
| 1013 | INVALID_OPERATION      | An invalid operation occurred.  |
| 1017 | CLIENT_SESSION_TIMEOUT | The BlackBerry Connect client session has timed out.                    |

| Code | Text Code                 | Description   |
|------|---------------------------|---|
| 1018 | OPERATION_FAILURE         | The operation failed due to an invalid object state.  |
| 1019 | RT_EXCEPTION              | The operation failed due to SIP-related errors.   |
| 1020 | PUBLISH_SUBSCRIBE_EXCPT   | The SIP Service request was rejected by the instant messaging server.                               |
| 1021 | DEPENDENT_REQUEST_FAILED  | A dependent request failed in this batch.   |
| 1023 | SELF_REFERENCE_DEPENDENCY | The request makes a self referential dependency.  |
| 1024 | UNKNOWN_BATCH_DEPENDENCY  | The request dependency reference is unknown or undefined.   |
| 1025 | ACTION_PENDING            | The request is currently in progress.   |
| 1026 | NOT_SUPPORTED_BY_SERVER   | The request by the BlackBerry Connect client is not supported by this BEMS-Connect service version. |
| 1027 | WRONG_SERVER              | The BlackBerry Connect client should connect to a different BEMS-Connect service.                   |
| 1028 | SERVER_BUSY               | The server is too busy.   |

### SendMessage

| Code | Text Code                         | Description   |
|------|-----------------------------------|---|
| 4000 | MSG_INVALID_OPERATION             | The method is invoked multiple times using the same asyncResult.  |
| 4001 | MSG_OPERATION_FAILURE             | The operation failed due to invalid object state.   |
| 4002 | REAL_TIME_FAILURE                 | The operation failed due to SIP-related errors.   |
| 4003 | MSG_REMOTE_FAILURE_RESPONSE       | The recipient contact doesn't respond to the establish request operation.                                   |
| 4004 | MSG_DND_FAILURE                   | The message is not sent because the recipient has a Do Not Disturb state specified.                         |
| 4005 | MSG_NOT_FEDERATED_OR_INVALID_user | The contact is outside of your organization and is not federated with your company, or the user is invalid. |

| Code | Text Code                   | Description                                     |
|------|-----------------------------|---|
| 4006 | INVITATION_FAILURE_RESPONSE | The recipient contact declined your invitation. |

### Accept Chats

| Code | Text Code                         | Description  |
|------|-----------------------------------|--|
| 7000 | INVALID_REQUESTID                 | An invitation is not available for the request ID.   |
| 7001 | ACCEPT_CHAT_RT                    | The user is unable to complete accepting chat.   |
| 7002 | AC_INVALID_PARAMS                 | BEMS-Connect service cannot accept the call because of invalid parameters.                                 |
| 7003 | AC_INVALID_OPERATION              | BEMS-Connect service cannot accept the call because of an invalid operation.                               |
| 4005 | MSG_NOT_FEDERATED_OR_INVALID_USER | The user is outside of your organization and is not federated with your company, or the user is incorrect. |
| 4006 | INVITATION_FAILURE_RESPONSE       | The recipient contact declined your invitation.  |

### BeginSession

| Code  | Text Code            | Description  |
|-------|----------------------|--|
| 10000 | REGISTRATION_ERROR   | An invitation is not available for the request ID.         |
| 10001 | AUTHENTICATION_ERROR | The user is unable to complete accepting the chat request. |

### TerminateSession

| Code  | Text Code         | Description  |
|-------|-------------------|--|
| 11000 | SESSION_NOT_FOUND | The BEMS-Connect service couldn't find the session ID. Have the user log in to BlackBerry Connect again. |
| 11001 | XML_EXCEPTION     | The BEMS-Connect service encountered a XML exception.  |

### AddContact

| Code  | Text Code           | Description   |
|-------|---------------------|---|
| 12000 | ADD_CONTACT_FAILURE | Failed to add the contact to the BlackBerry Connect client contact list.  |
| 12001 | ADD_CONTACT_EXISTS  | The contact already exists in the BlackBerry Connect client contact list. |

### RemoveContact

| Code  | Text Code              | Description  |
|-------|------------------------|--|
| 13000 | REMOVE_CONTACT_FAILURE | Contact does not exist in the BlackBerry Connect client. |

### BlockContact

| Code  | Text Code             | Description   |
|-------|-----------------------|---|
| 14001 | BLOCK_ALREADY_FAILURE | User is already blocked in the BlackBerry Connect client. |

### UnblockContact

| Code  | Text Code               | Description                    |
|-------|-------------------------|--------------------------------|
| 15000 | UNBLOCK_CONTACT_FAILURE | Failed to unblock user.        |
| 15001 | UNBLOCK_ALREADY_FAILURE | The user is already unblocked. |

### Active Directory

| Code  | Text Code                       | Description                                    |
|-------|---------------------------------|--|
| 26000 | ADCACHE_EXCEPTION               | Failed to setup ActiveDirectoryCache.          |
| 26001 | ADCACHE_SIP_NOT_FOUND_EXCEPTION | Failed to find the SIP address of the contact. |
| 26002 | ADCACHE_MULTIPLE_SIP_EXCEPTION  | The user has multiple SIP addresses.           |
| 26003 | ADCACHE_INVALID_USER_EXCEPTION  | The user is invalid.                           |



### RegisterTempRemotePresence

| Code  | Text Code                                    | Description                                  |
|-------|--|--|
| 27000 | REGISTER_TEMP_REMOTE_PRESENCE_EXCEPTION      | Failed to setup RegisterTempRemotePresence.  |
| 27001 | REGISTER_TEMP_REMOTE_PRESENCE_ALREADY_EXISTS | The user already exists in the Contact List. |

### UnregisterTempRemotePresence

| Code  | Text Code   | Description   |
|-------|---|---|
| 28000 | UNREGISTER_TEMP_REMOTE_PRESENCE_EXCEPTION                                     | Failed to setup RegisterTempRemotePresence.   |
| 28001 | UNREGISTER_TEMP_REMOTE_PRESENCE_USER_NOT_IN_CONTACTLIST_CONTACTLIST_EXCEPTION | The user is not in the BlackBerry Connect contact list.   |
| 28002 | UNREGISTER_TEMP_REMOTE_PRESENCE_BAD_TYPE_EXCEPTION                            | The user has the wrong type (for example, the userID is an object type instead of a string type). |

### NotifyBackground

| Code  | Text Code                        | Description  |
|-------|----------------------------------|--|
| 29001 | NOTIFYBACKGROUND_ALREADY_IN_MODE | The BlackBerry Connect app is already in the background. |

### StartChat

| Code  | Text Code           | Description  |
|-------|---------------------|--|
| 31031 | CHAT_DOES_NOT_EXIST | There is no existing chat conversation with the specified recipient contact.                 |
| 31032 | WRONG_CHAT_ID       | The existing chat conversation with the specified recipient contact has a different chat ID. |
| 31033 | CONTACT_OFFLINE     | The specified contact is not logged in.  |
| 31034 | NOT_CONTACT         | The specified user is not on the contact list.   |

## Persistent chat

| Code  | Text Code                    | Description   |
|-------|------------------------------|---|
| 40000 | PC_INVALID_OPERATION         | The endpoint is not in a valid state. An endpoint can only be established once and cannot be reused after being terminated.                                     |
| 40001 | PC_NULL_ARGUMENT             | The asyncResult parameter is a null value.  |
| 40002 | PC_COMMAND_FAILURE           | The endpoint is not in a valid state to be established or the connection call flow is interrupted.  |
| 40003 | PC_SERVER_CONNECTION_FAILURE | The PersistentChatEndpoint is not established, or the instant messaging server is not reachable, or the connection attempt is refused instant messaging server. |
| 40004 | PC_INVALID_PARAMS            | The method includes invalid parameters.   |
| 40005 | PC_GENERAL_FAILURE           | The BEMS-Connect service encountered a fatal error serving the persistent chat request.   |
| 40019 | PC_RT_EXCEPTION              | The session encountered an error communicating with the instant messaging server.   |
| 40020 | PC_SESSION_INVALID           | The session is in an invalid state. The State cannot be idle.   |
| 40021 | PC_INVALID_ARGUMENT          | The input parameters are invalid.   |
| 40025 | PC_MESSAGE_TOO_LONG          | The message is too long.  |
| 40100 | PC_NOT_SUPPORT_FAILURE       | The persistent chat service is not enabled for this user or instant messaging server.   |
| 40101 | PC_ROOM_STATE_FAILURE        | Group discussion is in an invalid state or the user did not join yet.   |
| 40102 | PC_ACCESS_DENIED             | The signed in user is not authorized to perform the action.   |
| 40103 | PC_DUPLICATE_ROOM_NAME       | A group discussion or category with that name already exists.   |
| 40104 | PC_ROOM_DISABLED             | The group discussion is disabled.   |
| 40105 | PC_ROOM_NOT_EXIST            | The group discussion does not exist.  |

| Code  | Text Code                      | Description   |
|-------|--------------------------------|---|
| 40106 | PC_ROOM_NAME_TOO_LONG          | The group discussion name is longer than 256 characters, spaces included.                                   |
| 40107 | PC_ROOM_HIERARCHY_FAILURE      | User cannot create rooms under the root category.   |
| 40109 | PC_CONNECTION_INTERRUPTED      | Connection flow interrupted. The endpoint is in an invalid state for the attempted operation.               |
| 40110 | PC_DATABASE_CONNECTION_FAILURE | There was a problem with the BEMS-Connect service connection to the Microsoft SQL Server database.          |
| 40111 | PC_DATA_COLLISION_FAILURE      | The object being modified has been changed. Refresh your copy of the object before attempting to modify it. |
| 40112 | PC_DUPLICATE_ADDIN_NAME        | There is an existing addin name.  |
| 40113 | PC_FILE_DOWNLOAD_FAILURE       | BEMS failed to download the file.   |
| 40114 | PC_FILE_UPLOAD_FAILURE         | BEMS failed to upload the file.   |
| 40115 | PC_INVALID_COMMAND_ARGUMENT    | One or more provided parameters to the command are invalid.   |
| 40116 | PC_INVALID_FILE_TRANSFER_TOKEN | Chat server (Lync/S4B) returned an invalid file transfer security token.                                    |
| 40117 | PC_LIMIT_EXCEEDED              | You have exceeded an internal server limit.   |
| 40118 | PC_MESSAGE_NOT_SUPPORTED       | The command is not supported by the BEMS-Connect service.   |
| 40119 | PC_NO_SUCH_PRINCIPAL_FAILURE   | One or more principals are invalid.   |
| 40122 | PC_PRINCIPALS_ALREADY_DEFINED  | The principals are already defined.   |
| 40123 | PC_PRINCIPALS_NOT_IN_SCOPE     | The principals are not in scope.  |
| 40124 | PC_SERVER_ERROR                | The instant messaging server reported an error. Refer to the exception message for the error code.          |
| 40125 | PC_CREATE_ROOM_FAILURE         | The signed in user cannot create the group discussion.  |
| 40126 | PC_UNKNOWN_SERVER_FAILURE      | An unknown error occurred on the server.  |

| Code  | Text Code  | Description   |
|-------|--|---|
| 40127 | PC_USER_NOT_JOINED_FAILURE                             | The signed in user has not joined to the group discussion.  |
| 40128 | PC_PARTICIPANT_LIST_FAILURE                            | The user can't request the participant list of the group discussion.  |
| 40129 | PC_DUPLICATE_ROOM_NAME_UPDATE_<br>UNKNOWN_SERVER_ERROR | An unknown error occurred on the Connect service. Updating the group discussion name with an existing room name may cause this error. |
| 40130 | PC_SAME_FILE_UPLOAD_NOT_ALLOWED                        | The file that is being uploaded to the specified group discussion is a duplicate. Duplicate uploads are not allowed.                  |
| 40131 | PC_FILE_POST_NOT_ALLOWED                               | File post operations are not allowed for the specified group discussion under category settings.                                      |

# Legal notice

©2024 BlackBerry Limited. Trademarks, including but not limited to BLACKBERRY, BBM, BES, EMBLEM Design, ATHOC, CYLANCE and SECUSMART are the trademarks or registered trademarks of BlackBerry Limited, its subsidiaries and/or affiliates, used under license, and the exclusive rights to such trademarks are expressly reserved. All other trademarks are the property of their respective owners.

Patents, as applicable, identified at: [www.blackberry.com/patents](http://www.blackberry.com/patents).

This documentation including all documentation incorporated by reference herein such as documentation provided or made available on the BlackBerry website provided or made accessible "AS IS" and "AS AVAILABLE" and without condition, endorsement, guarantee, representation, or warranty of any kind by BlackBerry Limited and its affiliated companies ("BlackBerry") and BlackBerry assumes no responsibility for any typographical, technical, or other inaccuracies, errors, or omissions in this documentation. In order to protect BlackBerry proprietary and confidential information and/or trade secrets, this documentation may describe some aspects of BlackBerry technology in generalized terms. BlackBerry reserves the right to periodically change information that is contained in this documentation; however, BlackBerry makes no commitment to provide any such changes, updates, enhancements, or other additions to this documentation to you in a timely manner or at all.

This documentation might contain references to third-party sources of information, hardware or software, products or services including components and content such as content protected by copyright and/or third-party websites (collectively the "Third Party Products and Services"). BlackBerry does not control, and is not responsible for, any Third Party Products and Services including, without limitation the content, accuracy, copyright compliance, compatibility, performance, trustworthiness, legality, decency, links, or any other aspect of Third Party Products and Services. The inclusion of a reference to Third Party Products and Services in this documentation does not imply endorsement by BlackBerry of the Third Party Products and Services or the third party in any way.

EXCEPT TO THE EXTENT SPECIFICALLY PROHIBITED BY APPLICABLE LAW IN YOUR JURISDICTION, ALL CONDITIONS, ENDORSEMENTS, GUARANTEES, REPRESENTATIONS, OR WARRANTIES OF ANY KIND, EXPRESS OR IMPLIED, INCLUDING WITHOUT LIMITATION, ANY CONDITIONS, ENDORSEMENTS, GUARANTEES, REPRESENTATIONS OR WARRANTIES OF DURABILITY, FITNESS FOR A PARTICULAR PURPOSE OR USE, MERCHANTABILITY, MERCHANTABILITY, NON-INFRINGEMENT, SATISFACTORY QUALITY, OR TITLE, OR ARISING FROM A STATUTE OR CUSTOM OR A COURSE OF DEALING OR USAGE OF TRADE, OR RELATED TO THE DOCUMENTATION OR ITS USE, OR PERFORMANCE OR NON-PERFORMANCE OF ANY SOFTWARE, HARDWARE, SERVICE, OR ANY THIRD PARTY PRODUCTS AND SERVICES REFERENCED HEREIN, ARE HEREBY EXCLUDED. YOU MAY ALSO HAVE OTHER RIGHTS THAT VARY BY STATE OR PROVINCE. SOME JURISDICTIONS MAY NOT ALLOW THE EXCLUSION OR LIMITATION OF IMPLIED WARRANTIES AND CONDITIONS. TO THE EXTENT PERMITTED BY LAW, ANY IMPLIED WARRANTIES OR CONDITIONS RELATING TO THE DOCUMENTATION TO THE EXTENT THEY CANNOT BE EXCLUDED AS SET OUT ABOVE, BUT CAN BE LIMITED, ARE HEREBY LIMITED TO NINETY (90) DAYS FROM THE DATE YOU FIRST ACQUIRED THE DOCUMENTATION OR THE ITEM THAT IS THE SUBJECT OF THE CLAIM.

TO THE MAXIMUM EXTENT PERMITTED BY APPLICABLE LAW IN YOUR JURISDICTION, IN NO EVENT SHALL BLACKBERRY BE LIABLE FOR ANY TYPE OF DAMAGES RELATED TO THIS DOCUMENTATION OR ITS USE, OR PERFORMANCE OR NON-PERFORMANCE OF ANY SOFTWARE, HARDWARE, SERVICE, OR ANY THIRD PARTY PRODUCTS AND SERVICES REFERENCED HEREIN INCLUDING WITHOUT LIMITATION ANY OF THE FOLLOWING DAMAGES: DIRECT, CONSEQUENTIAL, EXEMPLARY, INCIDENTAL, INDIRECT, SPECIAL, PUNITIVE, OR AGGRAVATED DAMAGES, DAMAGES FOR LOSS OF PROFITS OR REVENUES, FAILURE TO REALIZE ANY EXPECTED SAVINGS, BUSINESS INTERRUPTION, LOSS OF BUSINESS INFORMATION, LOSS OF BUSINESS OPPORTUNITY, OR CORRUPTION OR LOSS OF DATA, FAILURES TO TRANSMIT OR RECEIVE ANY DATA, PROBLEMS ASSOCIATED WITH ANY APPLICATIONS USED IN CONJUNCTION WITH BLACKBERRY PRODUCTS OR SERVICES, DOWNTIME COSTS, LOSS OF THE USE OF BLACKBERRY PRODUCTS OR SERVICES OR ANY PORTION THEREOF OR OF ANY AIRTIME SERVICES, COST OF SUBSTITUTE GOODS, COSTS OF COVER, FACILITIES OR SERVICES, COST OF CAPITAL, OR OTHER SIMILAR PECUNIARY LOSSES, WHETHER OR NOT SUCH DAMAGES

WERE FORESEEN OR UNFORESEEN, AND EVEN IF BLACKBERRY HAS BEEN ADVISED OF THE POSSIBILITY OF SUCH DAMAGES.

TO THE MAXIMUM EXTENT PERMITTED BY APPLICABLE LAW IN YOUR JURISDICTION, BLACKBERRY SHALL HAVE NO OTHER OBLIGATION, DUTY, OR LIABILITY WHATSOEVER IN CONTRACT, TORT, OR OTHERWISE TO YOU INCLUDING ANY LIABILITY FOR NEGLIGENCE OR STRICT LIABILITY.

THE LIMITATIONS, EXCLUSIONS, AND DISCLAIMERS HEREIN SHALL APPLY: (A) IRRESPECTIVE OF THE NATURE OF THE CAUSE OF ACTION, DEMAND, OR ACTION BY YOU INCLUDING BUT NOT LIMITED TO BREACH OF CONTRACT, NEGLIGENCE, TORT, STRICT LIABILITY OR ANY OTHER LEGAL THEORY AND SHALL SURVIVE A FUNDAMENTAL BREACH OR BREACHES OR THE FAILURE OF THE ESSENTIAL PURPOSE OF THIS AGREEMENT OR OF ANY REMEDY CONTAINED HEREIN; AND (B) TO BLACKBERRY AND ITS AFFILIATED COMPANIES, THEIR SUCCESSORS, ASSIGNS, AGENTS, SUPPLIERS (INCLUDING AIRTIME SERVICE PROVIDERS), AUTHORIZED BLACKBERRY DISTRIBUTORS (ALSO INCLUDING AIRTIME SERVICE PROVIDERS) AND THEIR RESPECTIVE DIRECTORS, EMPLOYEES, AND INDEPENDENT CONTRACTORS.

IN ADDITION TO THE LIMITATIONS AND EXCLUSIONS SET OUT ABOVE, IN NO EVENT SHALL ANY DIRECTOR, EMPLOYEE, AGENT, DISTRIBUTOR, SUPPLIER, INDEPENDENT CONTRACTOR OF BLACKBERRY OR ANY AFFILIATES OF BLACKBERRY HAVE ANY LIABILITY ARISING FROM OR RELATED TO THE DOCUMENTATION.

Prior to subscribing for, installing, or using any Third Party Products and Services, it is your responsibility to ensure that your airtime service provider has agreed to support all of their features. Some airtime service providers might not offer Internet browsing functionality with a subscription to the BlackBerry® Internet Service. Check with your service provider for availability, roaming arrangements, service plans and features. Installation or use of Third Party Products and Services with BlackBerry's products and services may require one or more patent, trademark, copyright, or other licenses in order to avoid infringement or violation of third party rights. You are solely responsible for determining whether to use Third Party Products and Services and if any third party licenses are required to do so. If required you are responsible for acquiring them. You should not install or use Third Party Products and Services until all necessary licenses have been acquired. Any Third Party Products and Services that are provided with BlackBerry's products and services are provided as a convenience to you and are provided "AS IS" with no express or implied conditions, endorsements, guarantees, representations, or warranties of any kind by BlackBerry and BlackBerry assumes no liability whatsoever, in relation thereto. Your use of Third Party Products and Services shall be governed by and subject to you agreeing to the terms of separate licenses and other agreements applicable thereto with third parties, except to the extent expressly covered by a license or other agreement with BlackBerry.

The terms of use of any BlackBerry product or service are set out in a separate license or other agreement with BlackBerry applicable thereto. NOTHING IN THIS DOCUMENTATION IS INTENDED TO SUPERSEDE ANY EXPRESS WRITTEN AGREEMENTS OR WARRANTIES PROVIDED BY BLACKBERRY FOR PORTIONS OF ANY BLACKBERRY PRODUCT OR SERVICE OTHER THAN THIS DOCUMENTATION.

BlackBerry Enterprise Software incorporates certain third-party software. The license and copyright information associated with this software is available at <http://worldwide.blackberry.com/legal/thirdpartysoftware.jsp>.

BlackBerry Limited  
2200 University Avenue East  
Waterloo, Ontario  
Canada N2K 0A7

BlackBerry UK Limited  
Ground Floor, The Pearce Building, West Street,  
Maidenhead, Berkshire SL6 1RL  
United Kingdom

Published in Canada